

SystemStak™ Valves

ISO 4401 size 07; 315 bar (4500 psi); up to 200 L/min (53 USgpm)

General Description



This range of stackable hydraulic controls are designed to be mounted under a size 7 directional valve such as Eaton DG*V-7, solenoid controlled and pilot operated. With their cartridge design they will provide a compact hydraulic circuit at reduced cost with the elimination of interconnecting piping. Servicing is simplified with access to working parts achieved without removing valves from an assembled stack.

The units are performance rated up to: 200 L/min (53 USgpm) 315/350 bar (4500/5000 psi)

The range comprises:

DGMX-7.....Pressure reducing module
 DGMC-7..... Pressure relief module
 DGMFN-7 Flow restrictor module
 DGMPC-7 Pilot operated check module

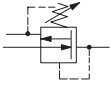
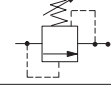
Table of Contents

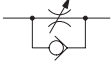
Function	Basic symbol	Basic model	Features	Page
Reducing		DGMX	Piloted from (and reduced pressure in) port P, A or B	3
Relief		DGMC	Single, dual and crossport models	5
Pilot operated check		DGMPC	Single in port A or B; dual in ports A and B	7
Flow restrictor		DGMFN	Single or dual port, meter-in or meter-out	10



SystemStak™ Pressure Reducing Valve Modules

DGMX-7

General Description

These two-stage adjustable pressure reducing modules are used to regulate the downstream pressure in the line in which the integral reducing valve is installed, whilst the upstream pressure fluctuates above the reduced pressure.

The valve elements are formed as cartridges for ease of construction and servicing.

Model Code

(F3-) DGMX-7 - P * - * - * -20

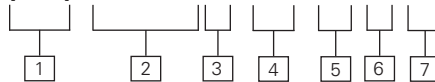

1 Special seals for phosphate ester fluids

Omit for standard seals; see "Hydraulic fluids" in "Further Information" section.

2 Stak Module Reducer

3 **Size**
ISO 4401-7

4 Function Ports

PP – pressure reducing function in the P line, piloted from P

PA – pressure reducing function in the P line, piloted from A

PB – pressure reducing function in the P line, piloted from B

5 Pressure adjustment range

B – 10 to 100 bar (145 to 1454 psi)

C – 10 to 160 bar (145 to 2326 psi)

F – 10 to 250 bar (145 to 3635 psi)

G – 350 bar (5000 psi)

6 Adjustment method

W – screw and lock nut

H – hand wheel with locknut

7 Design number,

Subject to change. Installation dimensions unchanged for numbers 20-29 inclusive.

Functional Symbol

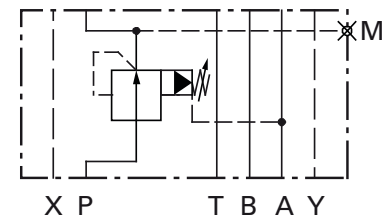
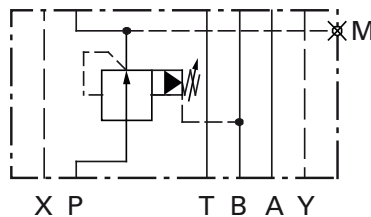
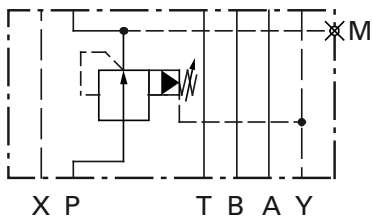

Operating Data

Basic Characteristics

Maximum flow	250 l/min (66 USgpm)
Maximum operating pressure	350 bar (5076 psi)
Operating temperature	-25 to +80°C (-13 to +176°F)
Pilot drain flow	0,5 L/min (0.13 USgpm)
Weights	8,65 kg (19.06 lb)

Performance Data

Performance Characteristics

Typical performance with petroleum oil at 36 cSt (169 SUS) and 50°C (122°F).

Reduced Pressure Underwrite

At cartridge outlet for various pressure settings.

Installation Dimensions in mm (inches)

DGMX-7

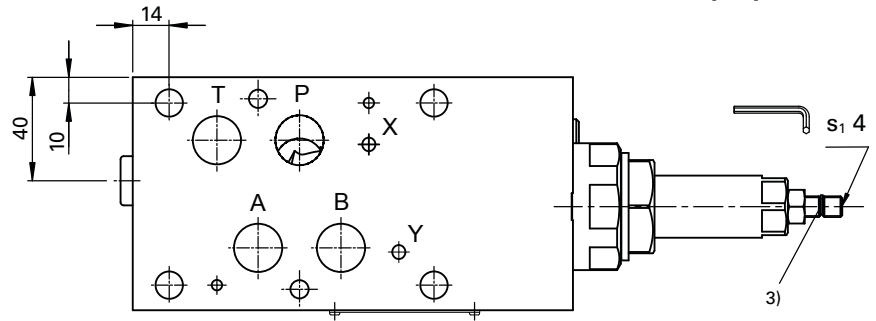
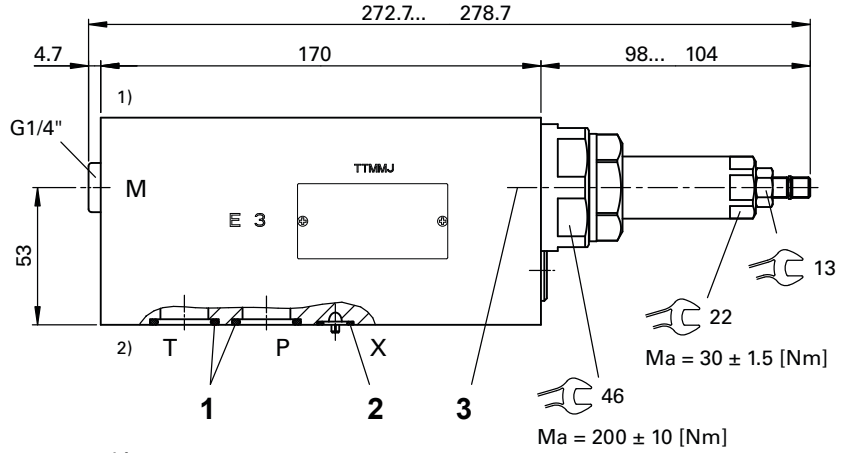
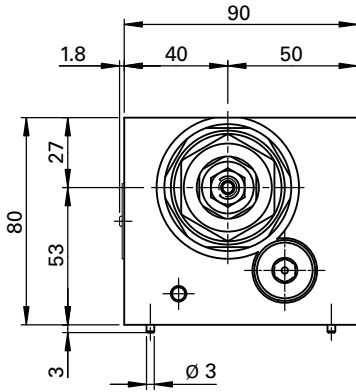

H Option- Hand Wheel

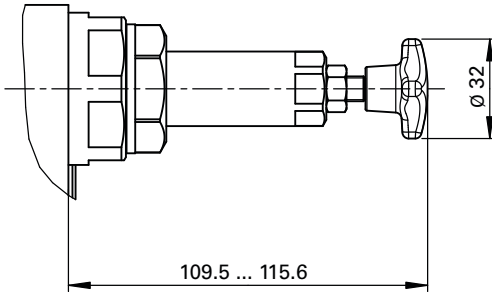

W Option- Screw and Locknut

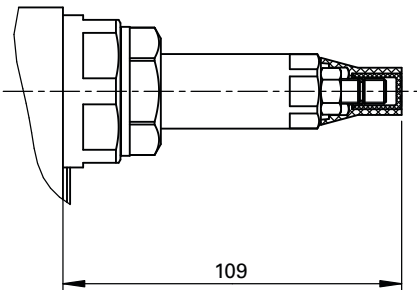

For all models, to increase pressure setting, unlock and turn the adjuster clockwise, viewed at the adjuster end. Turn counter-clockwise to decrease pressure setting.

Type H adjustment settings can be secured by tightening the lock screw in the end of the thimble.

For dimensions of ISO 4401, size 07 mounting surface and Eaton subplates, see catalog 2425.

For details of Eaton fixing bolt kits, see catalog 2314.

Pressure Relief Valve Modules

DGMC(2)-7

General Description

These two-stage adjustable pressure relief modules are used to limit the maximum pressure in the lines from which the integral relief elements are fed.

The relief elements are formed as cartridges for ease of construction and servicing.

Model Code

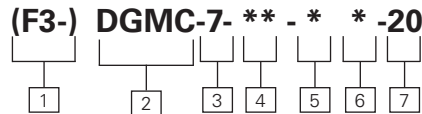

1 Special seals for phosphate ester fluids
Omit for standard seals; see "Hydraulic fluids" in "Further Information" section of catalog.

2 Stak Module Relief

3 Size
ISO 4401-07

4 Function
AT – Limits pressure in A, discharges to T
BT – Limits pressure in B, discharges to T
PT – Limits pressure in P, discharges to T

5 Pressure adjustment range
B – 10 to 100 bar (145 to 1454 psi)
C – 10 to 160 bar (145 to 2326 psi)
F – 10 to 250 bar (145 to 3635 psi)
G – 350 bar (5000 psi)

6 Adjustment method
W – screw and lock nut
H – hand wheel with lock nut

7 Design number, 20 series
Subject to change. Installation dimensions unchanged for design numbers 20-29 inclusive.

Functional Symbol

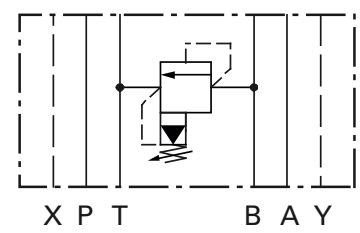
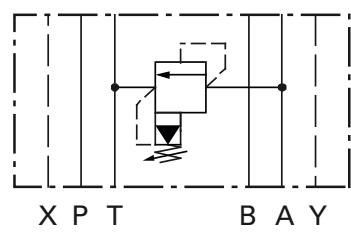
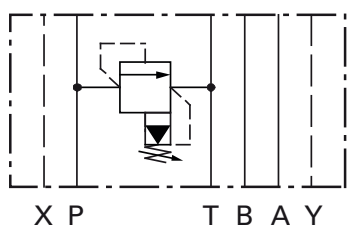

Operating Data

Basic Characteristics

Maximum flow	300 l/min (80 USgpm)
Maximum operating pressure	350 bar (5076 psi)
Note that back pressure in line T, into which the valve's pilot drain is internally connected, increases the effective pressure setting. For pressure adjustment ranges see "Model Code".	
Operating temperature	-25 to +80°C (-13 to +176°F)
Pilot drain flow	0,5 L/min (0.13 USgpm)
Weights	8,55 kg (18.84 lb)

Performance Characteristics

Typical performance with petroleum oil at 36 cSt (169 SUS) and 50°C (122°F).

Pressure Override at Cartridge Inlet

At various pressure settings and cartridge outlet at 0 bar/psi.

Performance Data

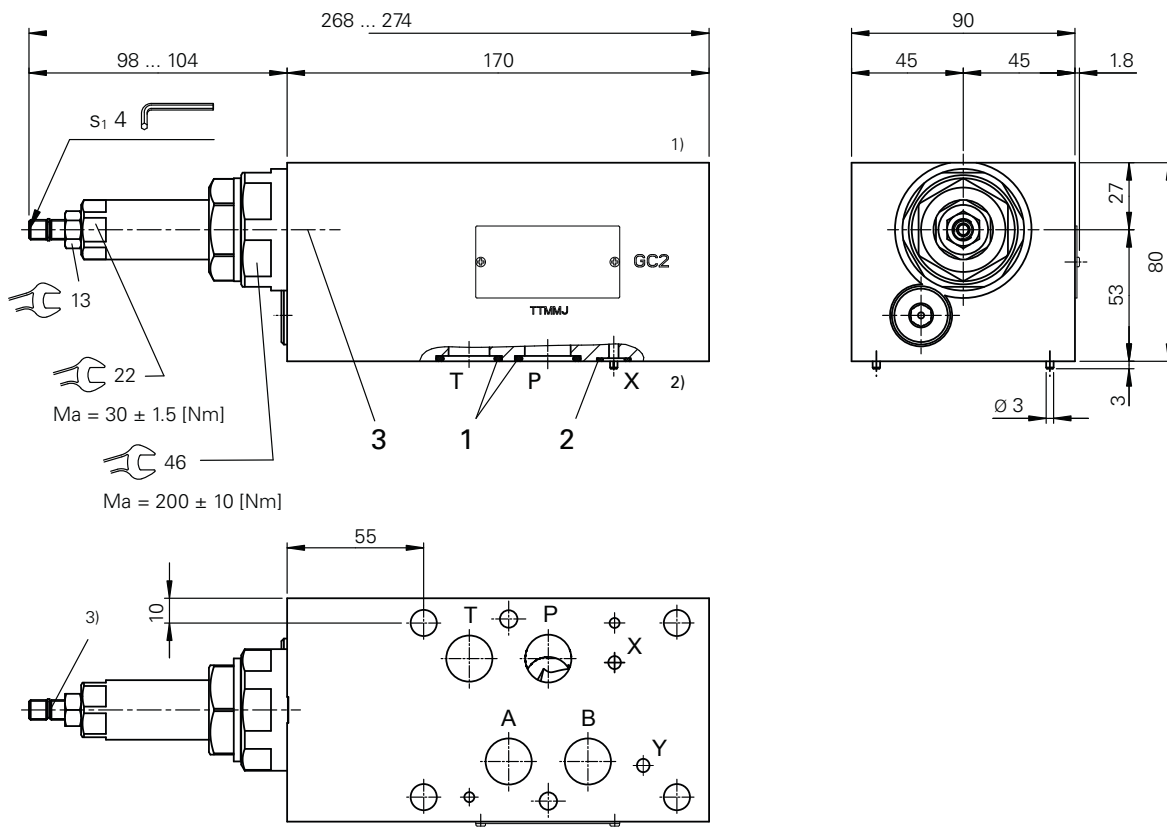

H Option - Hand Wheel

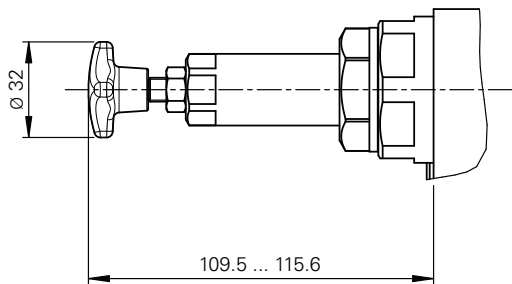

W Option - Screw and Locknut

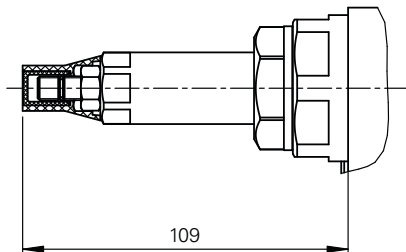

For all models, to increase pressure setting, unlock and turn the adjuster clockwise, viewed at the adjuster end. Turn counter-clockwise to decrease pressure setting.

Type H adjustment settings can be secured by tightening the lock screw in the end of the thimble.

For dimensions of ISO 4401, size 07 mounting surface and Eaton subplates, see catalog 2425.

For details of Eaton fixing bolt kits, see catalog 2314.

SystemStak™ Pilot Operated Check Valve

DGMPC-7

General Description

Features:

- Industry Standard Mounting, ISO 4001-7, NFPA T 3.51 M R1 and ANSI B 93.7 D07
- For use in vertical stacking assemblies
- For the leak free closure of one or both service ports

General

The DGMPC hydraulic operated check valve is of a sandwich plate design. They are used for leak-free closure of one or both service ports, even for long periods of time. Free flow occurs from A1 to A2 or B1 to B2. Flow in the opposite direction is blocked. The fluid flows from A1 to A2, the piston (1) is pressurised and is pushed to the right, thereby opening the ball poppet (2) which then opens the main poppet (3). In order to ensure correct closing of the valve, the service ports of the directional valve must be connected to tank in the neutral position (see typical circuit).

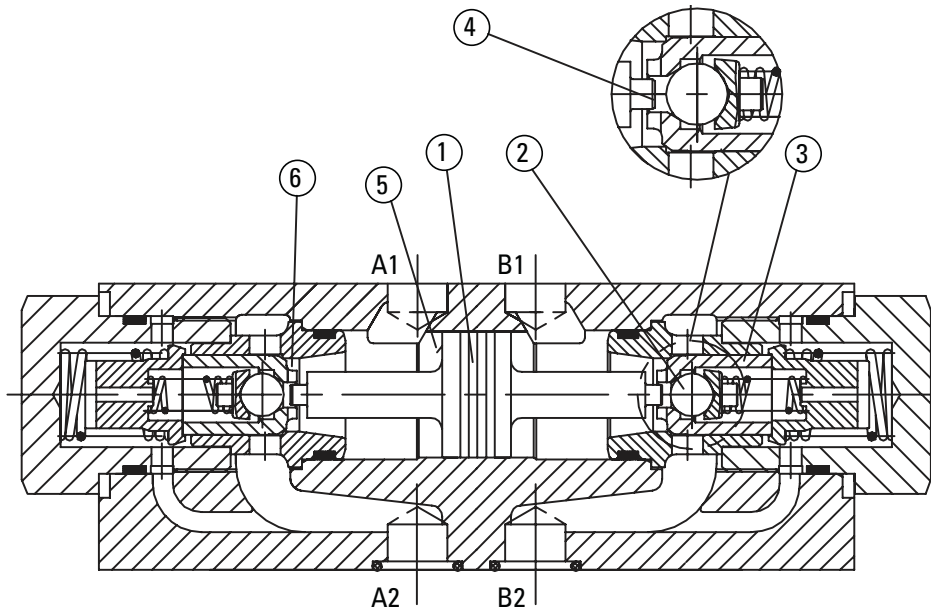

- 1 Piston
- 2 Ball Poppet
- 3 Main Poppet
- 4 Area A1
- 5 Area A2
- 6 Area A3

Model Code

(F3) - DGMPC - 7 - AB - *- (BA) - (*) - 30

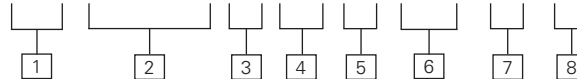

1 Seal Options

F3 – Fluorocarbon seals, for Phosphate Ester (class L-HFD)

Blank – Nitrile, for Mineral oil Anti-wear hydraulic oil (class L-HM), Invert emulsion (class L-HFB) Water glycol (class L-HFC)

2 Stack module, piloted operated check valve

3 **Size**
ISO 4401-07

4 Check Valve Line

AB – A piloted from B
BA – B piloted from A (Single line only)

5 Cracking Pressure

K – 3 Bar
L – 5 Bar
M – 7.5 Bar
N – 10 Bar

6 Check Valve Line

BA – B piloted from A (Dual line only)

7 Cracking Pressure (Dual line only)

K – 3 Bar
B – 5 Bar
M – 7.5 Bar
N – 10 Bar

8 Design Number

30

Functional Symbols

Typical Circuit

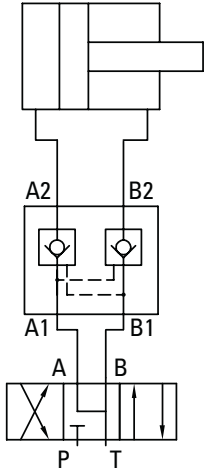

Symbols

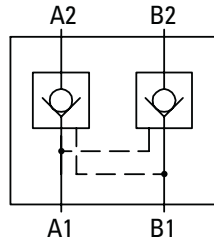

AB* - BA*

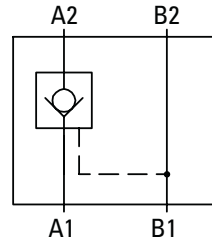

AB*

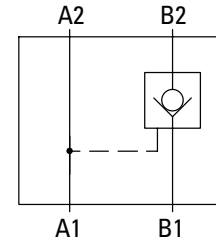

BA*

Operating Data

Technical Data

Maximum Flow (L/min)	300
Maximum Operating Pressure (bar)	315
Cracking Pressure	See "Characteristic Curves" graph
Area Ratio	A1/A2 = 1/11.8; A3/A2 = 1/2.8
Fluid	Mineral oils or phosphate ester
Fluid Temperature Range (OC)	-20 to 80
Fluid Viscosity Range (mm ² /S)	2.8 to 500
Fluid Cleanliness Level (ISO)	19/17/14
Weight (Kg)	6.5

Performance Data

Characteristic Curves
(measured at
 $v = 41 \text{ mm}^2/\text{s}$ and $t = 50^\circ\text{C}$)

Solid Line

A1 - A2; B1 - B2

Dotted Line

A2 - A1; B2 - B1

Cracking Pressure:

K = 3 bar
L = 5 bar
M = 7.5 bar
N = 10 bar

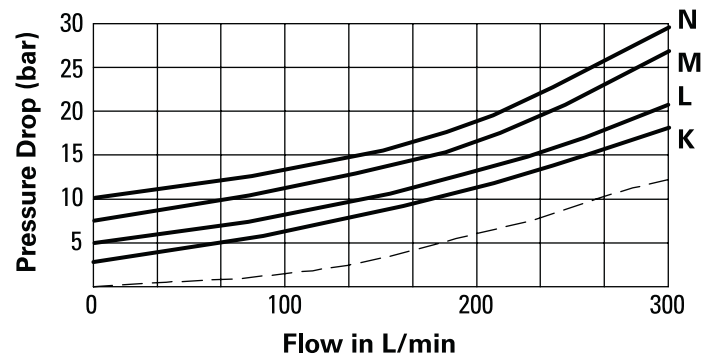

Installation Dimensions (in mm)

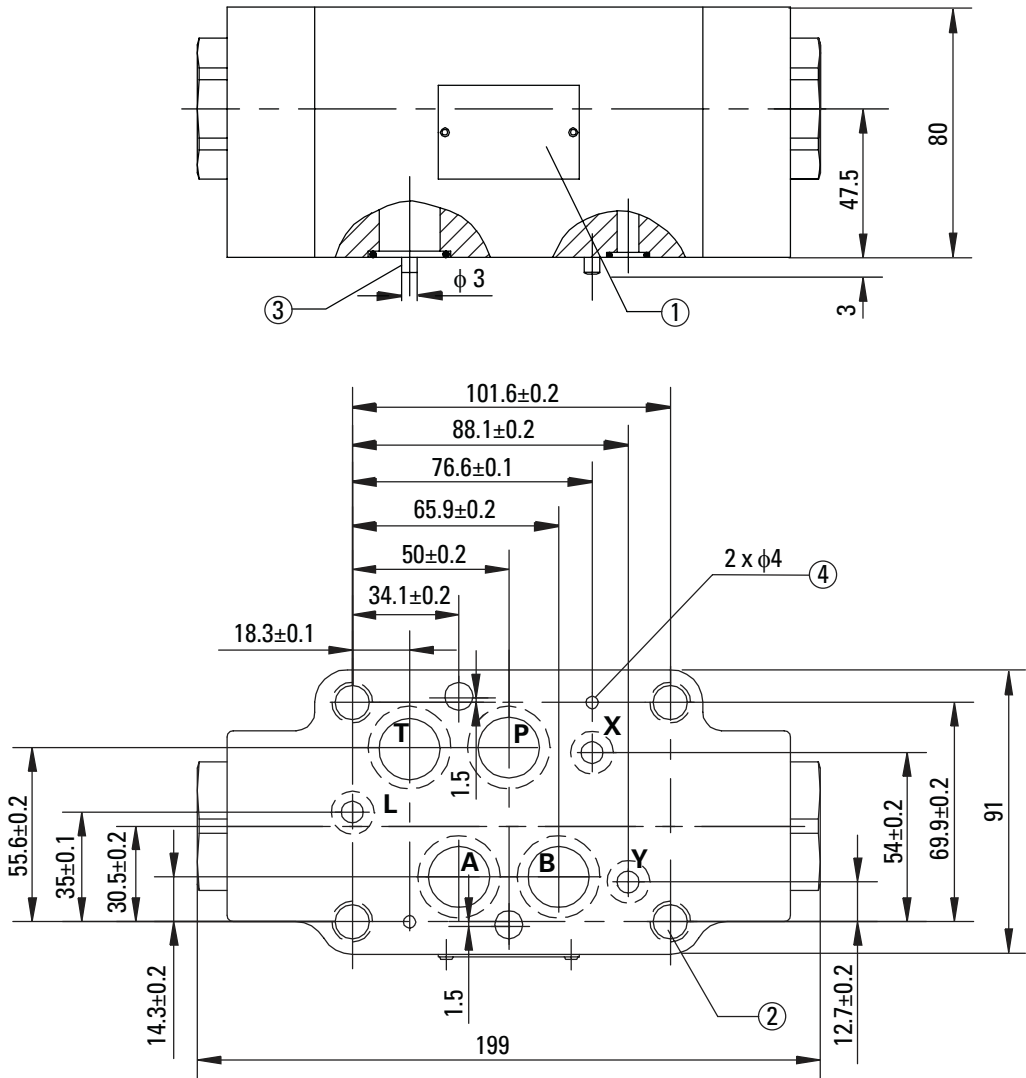

Required surface finish of mating face

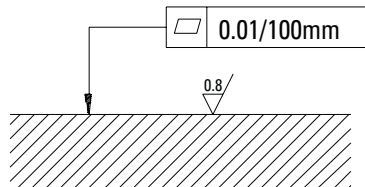

- 1 Name plate
- 2 Valve mounting holes
- 3 Locating pins
- 4 Locating pin holes

Mounting bolts: 3/8-18 (4) & 1/4-20 (2), SAE, Grade 8; M10 (4) & M6 (2), DIN912-10.9; ISO 898, Class 12.9
 O-rings: 22mm x 2.5mm for ports A,B,P and T.
 O-rings: 10mm x 2mm for ports X,Y, and L.

SystemStak™ Throttle Valve with Check

DGMFN-7

General Description

Features:

- Industry standard mounting, ISO 4401-7, NFPNA-T-3 .5.1-M-R-I, ANSI B 93.7 D07
- Sandwich plate design
- Limiting of main flow of two actuator ports
- Meter-in or meter-out control

General

DGMFN valves have double throttle/check valves in a sandwich plate design. They are used to limit main flow at one or two actuator ports. Two symmetrically arranged throttle/check valves limit flow (by means of adjustable throttle spools) in one direction and permit free return flow in the other direction.

Main flow limiting

The double throttle/check valve is fitted between the directional valve and the subplate to change the speed of an actuator (main flow limiting)

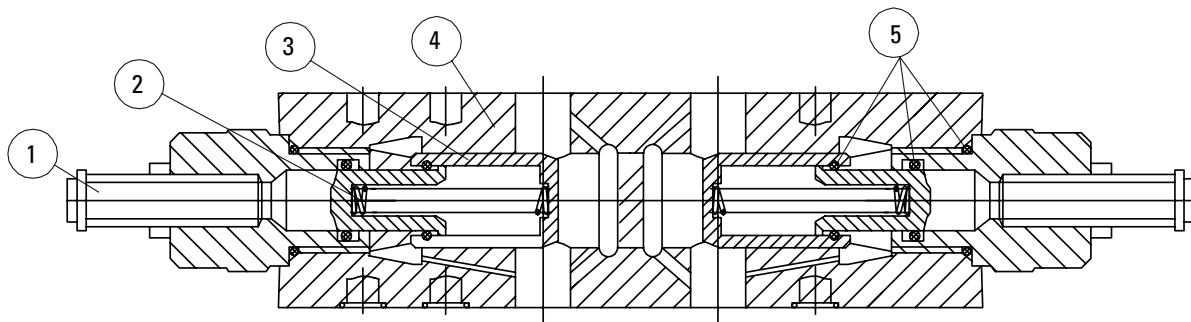

- 1 Throttle Adjustment Screw
- 2 Spring
- 3 Spool
- 4 Valve Body
- 5 O-Ring

Model Code

F3 - DGMFN - 7 - * - A2W - B2W - 30

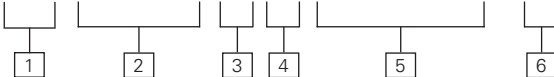

1 Seal Options

F3 – Fluorocarbon seals, for Phosphate Ester (class L-HFD)

Blank – Nitrile, for Mineral oil Anti-wear hydraulic oil (class L-HM), Invert emulsion (class L-HFB) Water glycol (class L-HFC)

2 Stack module, throttle valve with check

3 Size

ISO 4401-07

4 Direction of flow control

Y – Meter out
X – Meter in
YX – Meter out A, meter in B
XY – Meter in A, meter out B

5 Control line (Wrench adjustment)

Both port A and B

6 Design Number

30

Functional Symbols

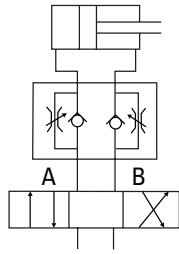

Meter-in control...X

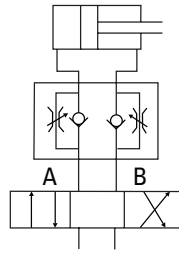

Meter-out control...Y

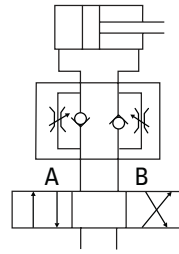

A Meter -out control
B Meter -in control: YX

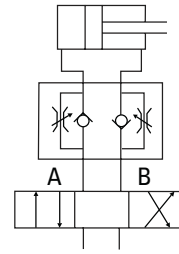

A Meter -in control
B Meter -out control: XY

Operating Data

Technical Data

Maximum Flow (L/min)	250
Maximum Working Pressure (bar)	315
Fluid	Mineral oils or phosphate ester
Fluid Temperature Range (0 C)	-20 to + 80
Fluid Viscosity Range (mm ² /S)	2.8 to 500
Fluid Cleanliness Level (ISO)	19/17/14
Weight (Kg)	4.7

Performance Data

Characteristic Curves
(measured at
 $v = 41 \text{ mm}^2/\text{s}$ and
 $t = 50^\circ\text{C}$)

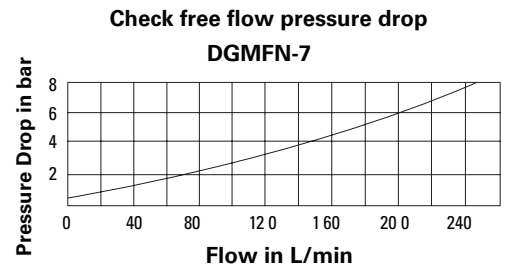
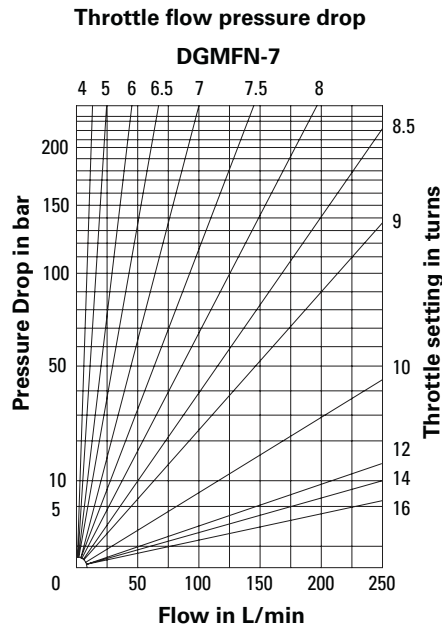

Installation Dimensions

(Dimensions in mm)

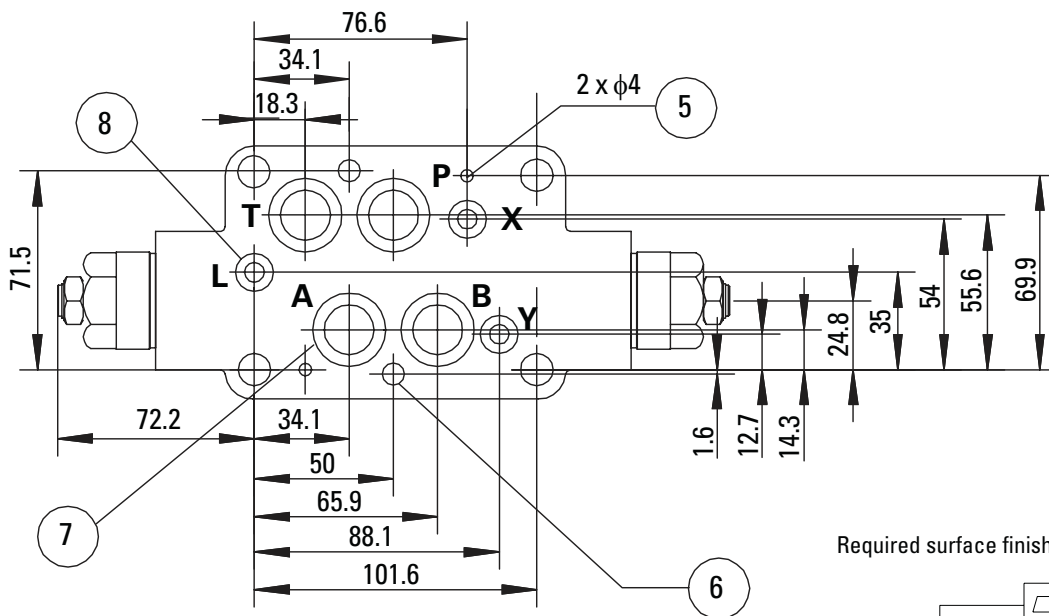
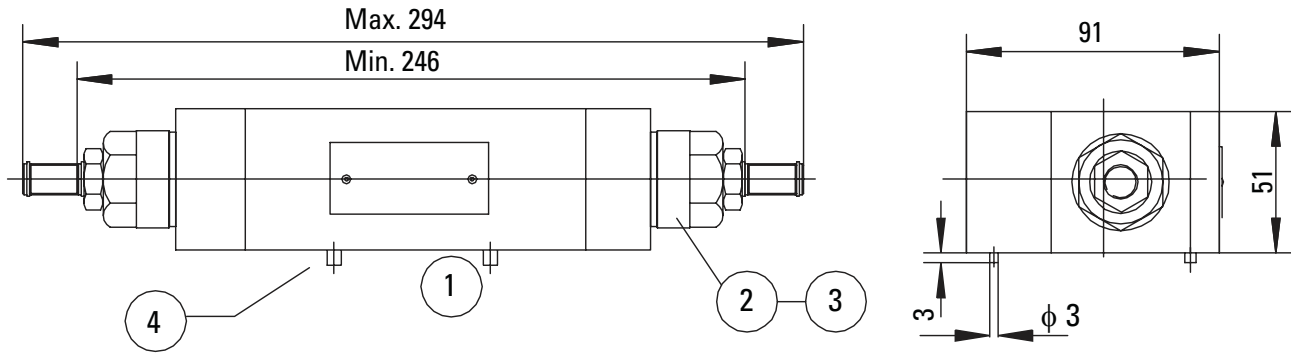

Required surface finish of mating face

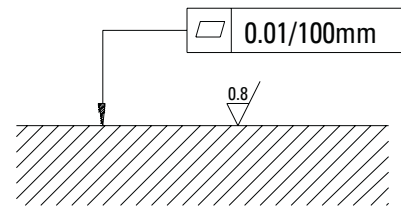

- 1 Name plate
- 2 Screw for flow adjustment
- 3 Turn anti-clockwise = increases flow, turn clockwise = decreases flow
- 4 Two locating pins
- 5 Two locating pin holes
- 6 Valve mounting holes
- 7 O-ring ports A,B,P,T
- 8 O-ring ports X,Y,L

Mounting bolts: ½-UNC, SAE, Grade 8; M10 (4) & M 6 (2) , DIN912-10.9; ISO 898, Class 12.9

O-Ring: size 22mm x 2.5mm for port A,B,P and T

O-Ring: size 10mm x 2mm for port X,Y, and L



Eaton
Hydraulics Business USA
14615 Lone Oak Road
Eden Prairie, MN 55344
USA
Tel: 952-937-9800
Fax: 952-294-7722
www.eaton.com/hydraulics

Eaton
Hydraulics Business Europe
Route de la Longeraie 7
1110 Morges
Switzerland
Tel: +41 (0) 21 811 4600
Fax: +41 (0) 21 811 4601

Eaton
Hydraulics Group Asia Pacific
Eaton Building
4th Floor, No. 3 Lane 280 Linhong Rd.
Changning District
Shanghai 200335
China
Tel: (+86 21) 5200 0099
Fax: (+86 21) 5200 0400