

Series 61 cylinders - Aluminium profile

Single and double-acting, magnetic, cushioned
Standard, low friction, low temperatures and tandem versions
Ø 32, 40, 50, 63, 80, 100, 125 mm



SERIES 61 CYLINDERS



Series 61 cylinders comply with the ISO 15552 standards and can be assembled with the entire range of standard accessories. A permanent magnet, mounted on the piston in these cylinders, enables information to be received regarding the piston position by means of proximity switches mounted in grooves along the cylinder profile. These grooves can be covered with a slot cover profile.

This cylinder series is equipped with adjustable end-stroke cushioning. Moreover, they are equipped with a mechanical cushioning in order to reduce the impact of the piston as it reaches the end of the stroke.

- » In compliance with ISO 15552 standards and with the previous DIN/ISO 6431 - VDMA 24562 standards
- » Rolled stainless steel rod
- » Clean design with adjustable pneumatic cushioning
- » Available special versions

TANDEM:

- » Double thrust and traction forces

LOW FRICTION:

- » Friction force reduced by over 40%

LOW TEMPERATURE:

- » Versions for -40°C and for -50°C

G VARIANT FOR DUSTY APPLICATIONS:

- » Highly resistant to dust, cement, resin, mud and wood residue

GENERAL DATA

Type of construction	with tie-rods (inside the profile)
Operation	double-acting, single-acting, tandem. Low friction version: double-acting only.
Design	ISO 15552
Materials	standard: AL end-blocks and piston, rolled stainless steel AISI 420B rod, anodized AL profile tube, zinc-plated steel tie-rods and tie-rod nuts, PU seals; low friction: standard materials with NBR piston seal and NBR rod seal (FKM rod seal on request) low temperature: standard materials with chrome plated stainless steel AISI 420B rod, brass rod scraper ring, stainless steel AISI 303 nuts, stainless steel AISI 420B tie-rods, PU piston seals and NBR rod seal
Type of mounting	with front / rear flange, foot mounting, with front / rear / centre / swivel trunnion
Stroke min - max	10 ÷ 2500 mm
Operating temperature	standard and low friction: 0°C ÷ 80°C (with dry air -20°C) low temperature (-40°C version): -40°C ÷ 60°C (with dry air -40°C) low temperature (-50°C version): -50°C ÷ 60°C (with dry air -50°C)
Operating pressure	1 ÷ 10 bar (standard and low temperature); 0,1 ÷ 10 bar (low friction)
Speed	10 ÷ 1000 mm/sec, no load (standard and low temperature); 5 ÷ 1000 mm/sec, no load (low friction)
Fluid	filtered air, without lubrication. For standard versions only: if lubricated air is used, it is recommended to use oil ISOVG32. Once applied the lubrication should never be interrupted.

STANDARD STROKES FOR CYLINDERS SERIES 61

■ = Single-acting (standard and low temperature) ✕ = Double-acting (standard, low friction and low temperature)
 Other strokes up to 2500 mm are available on request.

STANDARD STROKES														
∅	25	50	75	80	100	125	150	160	200	250	300	320	400	500
32	■ ✕	■ ✕	■ ✕	✕	✕	✕	✕	✕	✕	✕	✕	✕	✕	✕
40	■ ✕	■ ✕	■ ✕	✕	✕	✕	✕	✕	✕	✕	✕	✕	✕	✕
50	■ ✕	■ ✕	■ ✕	✕	✕	✕	✕	✕	✕	✕	✕	✕	✕	✕
63	■ ✕	■ ✕	■ ✕	✕	✕	✕	✕	✕	✕	✕	✕	✕	✕	✕
80	■ ✕	■ ✕	■ ✕	✕	✕	✕	✕	✕	✕	✕	✕	✕	✕	✕
100		■ ✕	■ ✕	✕	✕	✕	✕	✕	✕	✕	✕	✕	✕	✕
125		✕	✕	✕	✕	✕	✕	✕	✕	✕	✕	✕	✕	✕

CODING EXAMPLE

61	M	2	P	050	A	0200	
-----------	----------	----------	----------	------------	----------	-------------	--

61	SERIES
M	VERSION M = standard, magnetic L = low friction, magnetic
2	OPERATION 1 = single-acting, front spring (∅ 32 ± ∅ 100) 2 = double-acting, front and rear cushioned 3 = double-acting, no cushion 4 = double-acting, rear cushioned 5 = double-acting, front cushioned 6 = double-acting, through-rod, front and rear cushioned 7 = single-acting, through-rod 8 = double-acting, through-rod, no cushion
P	MATERIALS P = see the GENERAL DATA table on the previous page R = stainless steel AISI 420B tie-rods, stainless steel AISI 303 tie-rod nuts, other materials (see the previous page) C = rolled stainless steel AISI 303 piston rod, stainless steel AISI 304 piston rod nut U = rolled stainless steel AISI 303 piston rod, AISI 304 piston-rod nut, AISI 420B tie-rods, AISI 303 tie-rod nuts W = rolled stainless steel AISI 304 piston rod, AISI 304 piston-rod nut, AISI 420B tie-rods, AISI 303 tie-rod nuts Z = chrome plated stainless steel AISI 420B rod, stainless steel AISI 304 rod nut, stainless steel AISI 420B tie-rods, stainless steel AISI 303 tie-rod nuts, seals for low temperature (-40°C), brass rod scraper Y = chrome plated stainless steel AISI 420B rod, stainless steel AISI 304 rod nut, stainless steel AISI 420B tie-rods, stainless steel AISI 303 tie-rod nuts, seals for low temperature (-50°C), brass rod scraper
050	BORE 032 = 32 mm - 040 = 40 mm - 050 = 50 mm - 063 = 63 mm - 080 = 80 mm - 100 = 100 mm - 125 = 125 mm
A	CONSTRUCTION A = standard with rod nut - RL = cylinder with rod lock
0200	STROKE (see the table) = standard V = FKM rod seal N = tandem (pneumatic symbol: CD8T) R = NBR rod seal W = all FKM seals +130°C C = PU coated cylinder. Colour: Grey* L = low friction version without rod seal (rear supply only)** (_ _ _) = extended piston rod _ _ _ mm G = with brass rod scraper (chrome plated stainless steel AISI 420B rod, NBR rod seal) * Version C: available on request. For further information, please contact our technical dept. ** The possibility to order the cylinder without piston rod seal, further reduces the friction force.

Note: all double-acting cylinders are also available in the low friction version.

PNEUMATIC SYMBOLS

The pneumatic symbols which have been indicated in the CODING EXAMPLE are shown below.

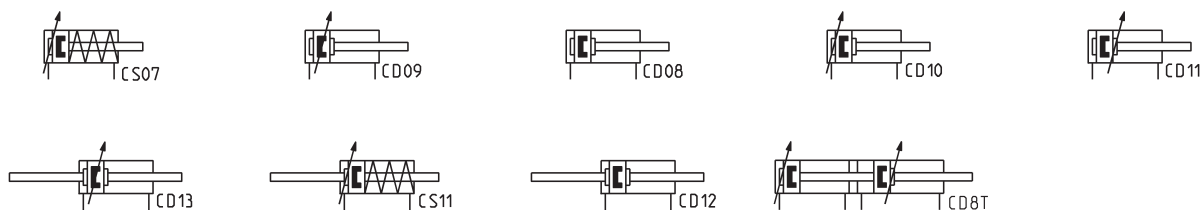

Series 61 low friction cylinders - APPLICATION EXAMPLES

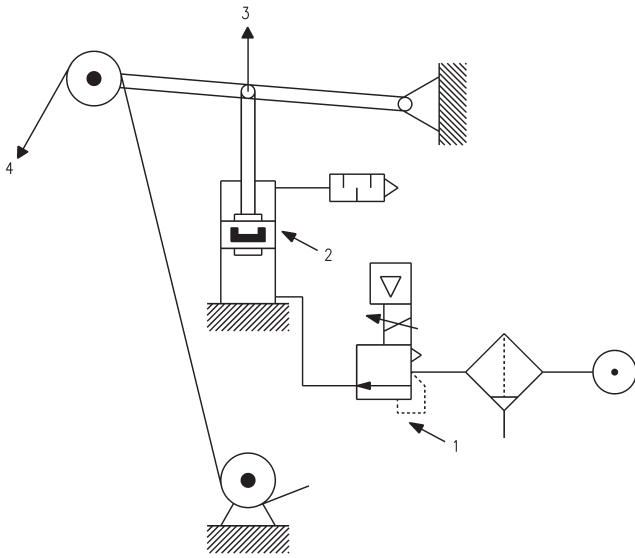

CYLINDER IN THRUST

DRAWING NOTES:

- 1. Precision pressure regulator or proportional regulator
- 2. Low friction cylinder
- 3. Force direction
- 4. Band

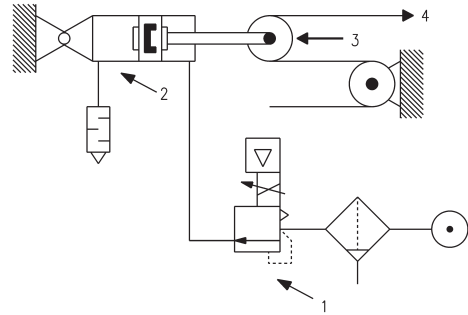

CYLINDER IN TRACTION

Note: in order to reach the highest performance, it is recommended to connect a precision pressure regulator or a proportional regulator with the low friction cylinder as shown in the drawing.

Series 61 low temperatures cylinders - DETAIL

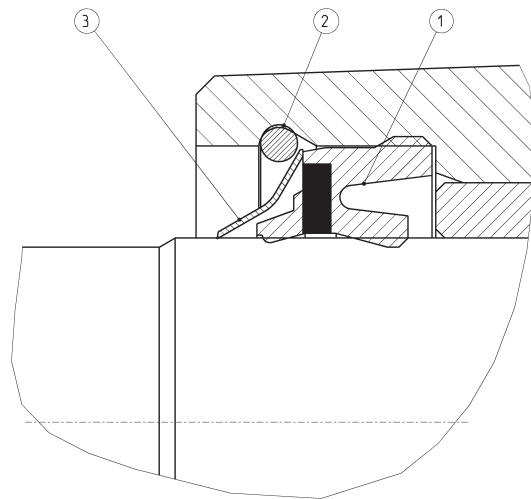
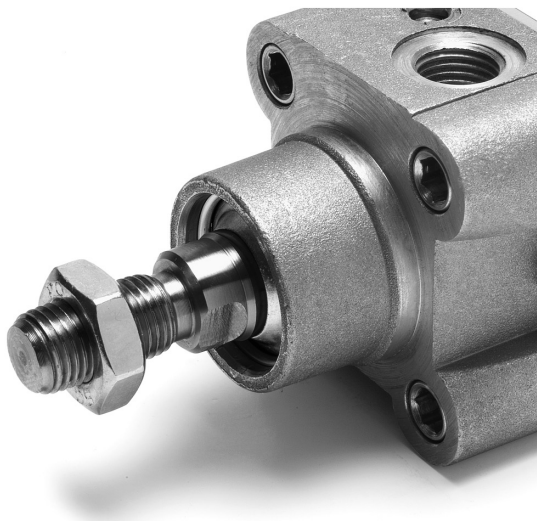

- 1 = rod seal
- 2 = flexible ring
- 3 = metal scraper

CYLINDERS ACCESSORIES SERIES 61



Piston rod socket joint
Mod. GY



Piston rod lock nut
Mod. U



Clevis pin Mod. S

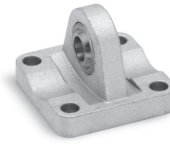

Rear trunnion ball-joint
Mod. R



Coupling piece
Mod. GKF



Swivel ball joint Mod. GA

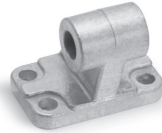

90° male trunnion
Mod. ZC

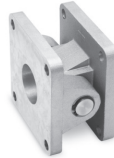

Swivel Combination
Mod. C+L+S

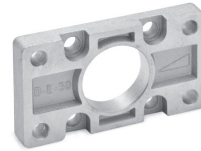

Front and rear flange Mod.
D-E



Self aligning rod
Mod. GK



Centre trunnion Mod. F



Foot mount Mod. B

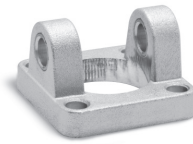

Front female trunnion
Mod. H and C-H

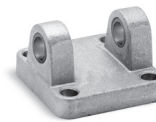

Rear female trunnion
Mod. C and C-H

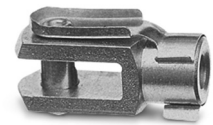

Rod fork end Mod. G

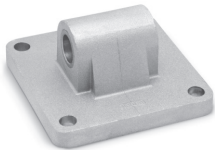

Rear trunnion male
Mod. L



Key to disassemble
cylinders Ø 80 and 100



Counter bracket for
centre trunnion Mod. BF



All accessories are supplied separately, except for piston rod lock nut Mod. U

Cylinders Series 61

N.B. : the single-acting cylinders, sizes ZJ and L2 are increased by 25 mm.



+ = add the stroke

Table note:
* = special key 80-62/8C
(see accessories)

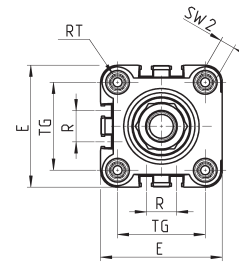
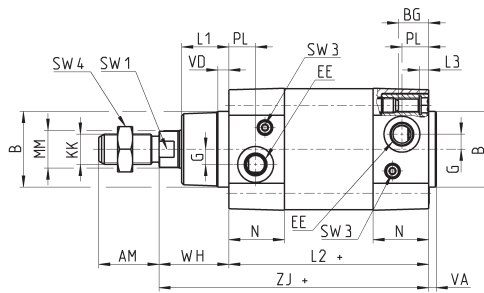

Ø32-40-50-63-125



SW 2



Ø80-100

DIMENSIONS

Ø	AM	B	BG	E	EE	G	KK	L1	L2+	L3	MM	N	PL	R	RT	SW1	SW2	SW3	SW4	TG	VA	VD	WH	ZJ+	front/rear cushion stroke
32	22	30	16	46	G1/8	5	M10x1,25	18	94	5	12	26	14	13	M6	10	6	2	17	32,5	4	5	26	120	17 / 12
40	24	35	16	55	G1/4	5	M12x1,25	21	105	5	16	29	15	13,5	M6	13	6	2	19	38	4	5	30	135	20 / 17
50	32	40	16	64,5	G1/4	8	M16x1,5	25	106	5	20	29,5	15	16	M8	17	8	3	24	46,5	4	6	37	143	15 / 14
63	32	45	16	75	G3/8	8	M16x1,5	26	121	5	20	36,5	21	28	M8	17	8	3	24	56,5	4	6	37	158	17 / 16
80	40	45	19	93	G3/8	8	M20x1,5	30	128	0	25	36	21	30	M10	22	*	5	30	72	4	7	46	174	20 / 20
100	40	55	19,5	110	G1/2	8	M20x1,5	35	138	0	25	38,5	23	40	M10	22	*	5	30	89	4	7	51	189	21 / 19
125	54	60	23	135	G1/2	10,5	M27x2	42	160	0	32	43	23,5	50	M12	27	12	4	41	110	6	8	65	225	26 / 25

Cylinders Series 61 - through-rod

Note: the single-acting cylinders sizes ZM and L2 are increased by 25 mm.



+ = add the stroke once
++ = add the stroke twice

Table note:
* = special key 80-62/8C
(see accessories)

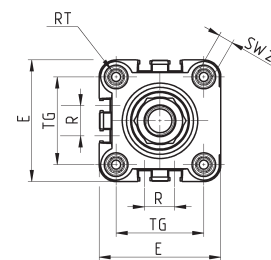
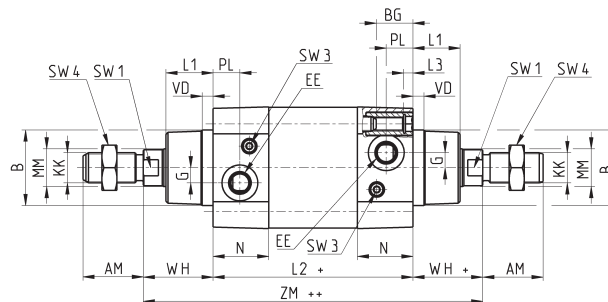

Ø32-40-50-63-125



SW 2



Ø80-100

through-rod

Ø	AM	B	BG	E	EE	G	KK	L1	L2+	L3	MM	N	PL	R	RT	SW1	SW2	SW3	SW4	TG	VD	WH	ZM++	Cushioning stroke
32	22	30	16	46	G1/8	5	M10x1.25	18	94	5	12	26	14	13	M6	10	6	2	17	32.5	5	26	146	17
40	24	35	16	55	G1/4	5	M12x1.25	21	105	5	16	29	15	13.5	M6	13	6	2	19	38	5	30	165	20
50	32	40	16	64.5	G1/4	8	M16x1.5	25	106	5	20	29.5	15	16	M8	17	8	3	24	46.5	6	37	180	15
63	32	45	16	75	G3/8	8	M16x1.5	26	121	5	20	36.5	21	28	M8	17	8	3	24	56.5	6	37	195	17
80	40	45	19	93	G3/8	8	M20x1.5	30	128	0	25	36	21	30	M10	22	*	5	30	72	7	46	220	20
100	40	55	19.5	110	G1/2	8	M20x1.5	35	138	0	25	38.5	23	40	M10	22	*	5	30	89	7	51	240	21
125	54	60	23	135	G1/2	10.5	M27x2	42	160	0	32	43	23.5	50	M12	27	12	4	41	110	8	65	290	26

Cylinders Series 61 - tandem version



+ = add the stroke once
 ++ = add the stroke twice
 1 = Cylinder's outlet
 2 = Cylinder's return

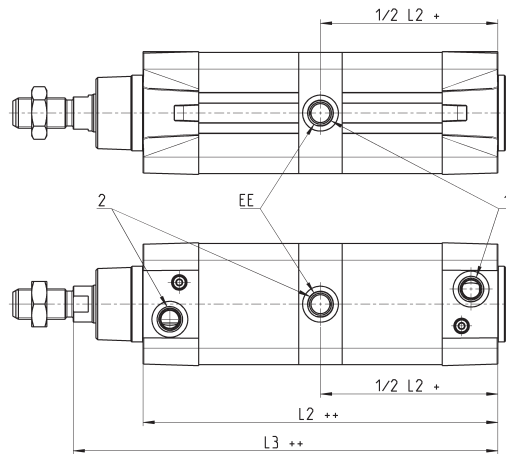

DIMENSIONS			
∅	EE	L2+	L3+
32	G1/8	172,5	197,5
40	G1/4	191,5	221,5
50	G1/4	188	225
63	G3/8	204	241
80	G3/8	225,5	271,5
100	G1/2	231	282
125	G1/2	264	329

Cylinders Series 61 with rod lock



+ = add the stroke

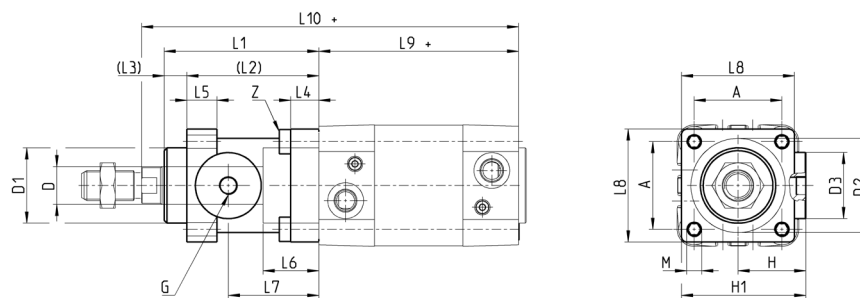

DIMENSIONS																				
∅	∅D	∅D1	∅D2	∅D3	A	G	H	H1	L1	L2	L3	L4	L5	L6	L7	L8	L9+	L10+	M	Z
32	12	30.5	35	25	32,5	M5	25,5	46,5	58	48	10	8	13	20,5	34	45	94	160	M6	M6x20
40	16	35	40	28	38	G1/8	30	53	65	55	10	8	13	22,5	38	50	105	178	M6	M6x20
50	20	40	50	35	46,5	G1/8	36	64	82	70	12	15	16	29,5	48	60	106	200	M8	M6x20
63	20	45	60	38	56,5	G1/8	40	75	82	70	12	15	16	29,5	49,5	70	121	215	M8	M8x30
80	25	45	80	48	72	G1/8	50	95	110	90	20	18	20	35	61	90	128	254	M10	M10x35
100	25	55	100	58	89	G1/8	58	110,5	115	100	15	18	20	39	69	105	138	269	M10	M10x35
125	32	60	130	65	110	G1/8	80	150	167	122	45	22	30	51	86,5	140	160	350	M12	M12x40

Foot mount Mod. B

Material: zinc-plated steel



Supplied with:
2x feet
4x screws
+ = add the stroke

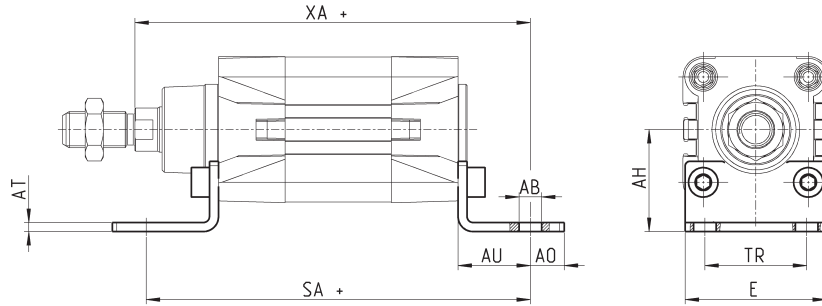

Mod.	∅	AT	SA+	XA+	TR	E	AB	AH	AO	AU	torque force
B-41-32	32	4	142	144	32	45	7	32	11	24	5 Nm
B-41-40	40	4	161	163	36	53,5	10	36	15	28	5 Nm
B-41-50	50	4	170	175	45	62,5	10	45	15	32	10 Nm
B-41-63	63	5	185	190	50	73	10	50	15	32	10 Nm
B-41-80	80	6	210	216	63	92	12	63	20	41	15 Nm
B-41-100	100	6	220	230	75	108,5	14,5	71	25	41	15 Nm
B-41-125	125	7	250	270	90	132	16,5	90	25	45	20 Nm

Front and rear flange Mod. D-E

Material: Aluminium

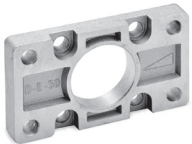

Supplied with:
1x flange
4x screws
+ = add the stroke

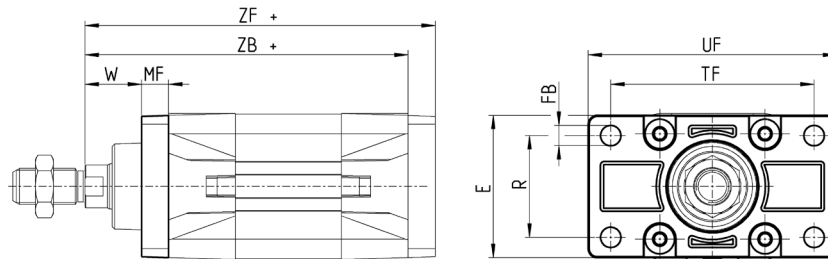

Mod.	∅	W	MF	ZB+	TF	R	UF	E	FB	ZF+	torque force
D-E-41-32	32	16	10	120	64	32	86	45	7	130	5 Nm
D-E-41-40	40	20	10	135	72	36	88	52	9	145	5 Nm
D-E-41-50	50	25	12	143	90	45	110	63	9	155	10 Nm
D-E-41-63	63	25	12	158	100	50	116	73	9	170	10 Nm
D-E-41-80	80	30	16	174	126	63	148	95	12	190	15 Nm
D-E-41-100	100	35	16	189	150	75	176	115	14	205	15 Nm
D-E-41-125	125	45	20	225	180	90	224	135	16	245	20 Nm

Rear female trunnion Mod. C and C-H

Material: Aluminium

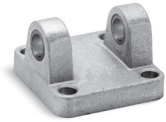

Supplied with:
1x female trunnion
4x screws

+ = add the stroke

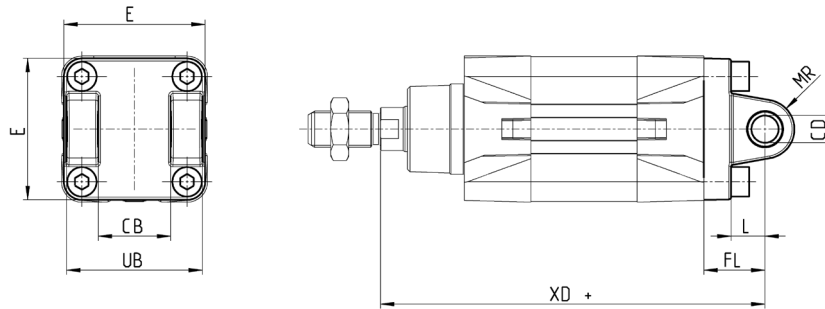

Mod.	∅	CD	L	FL	XD+	MR	E	CB	UB	torque force
C-41-32	32	10	12	22	142	10	45	26	45	5 Nm
C-41-40	40	12	15	25	160	12	53.5	28	52	5 Nm
C-41-50	50	12	15	27	170	13	62.5	32	60	10 Nm
C-H-41-63	63	16	20	32	190	17	73	40	70	10 Nm
C-H-41-80	80	16	24	36	210	17	92	50	90	15 Nm
C-H-41-100	100	20	29	41	230	21	108.5	60	110	15 Nm
C-H-41-125	125	25	30	50	275	26	132	70	130	20 Nm

Front female trunnion Mod. H and C-H

Material: Aluminium

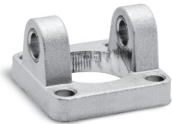

Supplied with:
1x female trunnion
4x screws

+ = add the stroke

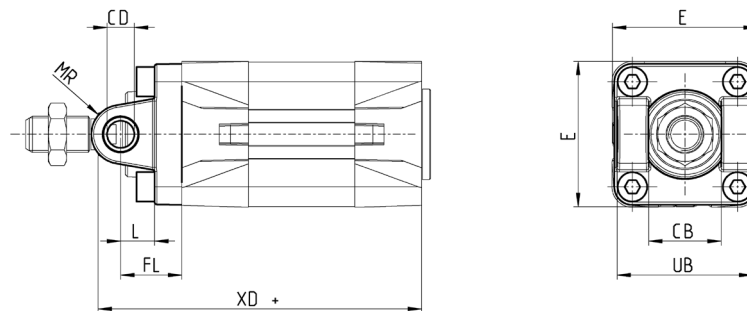

Mod.	∅	CB	UB	E	XD	FL	L	CD	MR	torque force
H-41-32	32	26	45	45	120	22	12	10	10	5 Nm
H-41-40	40	28	52	53.5	135	25	15	12	12	5 Nm
H-41-50	50	32	60	62.5	143	27	15	12	13	10 Nm
H-60-63	63	40	70	73	158	32	20	16	17	10 Nm
C-H-41-80	80	50	90	92	174	36	24	16	17	15 Nm
C-H-41-100	100	60	110	108.5	189	41	29	20	21	15 Nm
C-H-41-125	125	70	130	132	225	50	30	25	26	20 Nm

Rear male trunnion Mod. L

Material: Aluminium

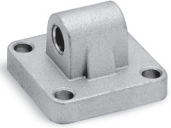

Supplied with:
1x male trunnion
4x screws

+ = add the stroke

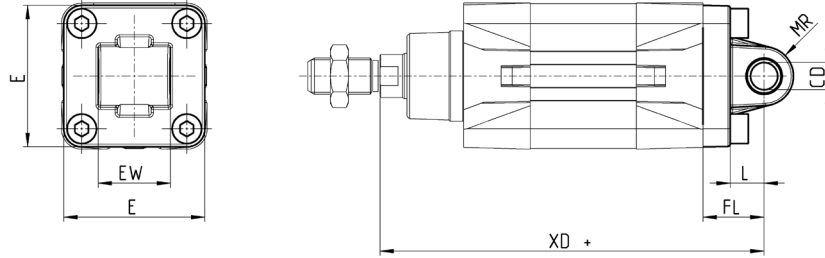

DIMENSIONS										
Mod.	∅	CD	L	FL	XD+	MR	E	EW	torque force	
L-41-32	32	10	12	22	142	10	45	26	5 Nm	
L-41-40	40	12	15	25	160	13	53.5	28	5 Nm	
L-41-50	50	12	15	27	170	13	62.5	32	10 Nm	
L-41-63	63	16	20	32	190	17	73	40	10 Nm	
L-41-80	80	16	24	36	210	17	92	50	15 Nm	
L-41-100	100	20	29	41	230	21	108.5	60	15 Nm	
L-41-125	125	25	30	50	275	26	132	70	20 Nm	

Centre trunnion Mod. F

Material: zinc-plated steel



Supplied with:
1x centre trunnion
4x screws
4x fixing elements

+ = add the stroke

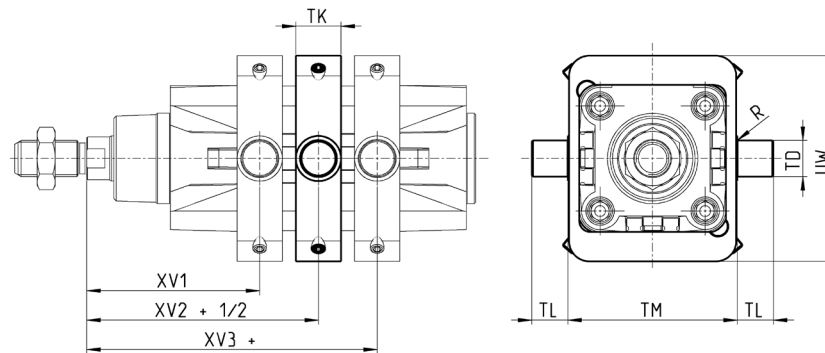

DIMENSIONS										
Mod.	∅	XV1	XV2	XV3	TM	TK	TD	TL	UW	R
F-61-32	32	61	73	85	50	18	12	12	65	0,1
F-61-40	40	69	82,5	96	63	20	16	16	75	0,15
F-61-50	50	76,5	90	103,5	75	20	16	16	91	0,15
F-61-63	63	86	97,5	109	90	25	20	20	94	0,15
F-61-80	80	94,5	110	125,5	110	25	20	20	130	0,15
F-61-100	100	104,5	120	135,5	132	30	25	25	145	0,2
F-61-125	125	123	145	167	160	30	25	25	155	0,2

Accessory combination Mod. C+L+S

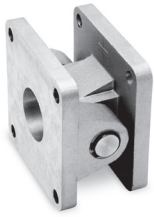

Material: aluminium

+ = add the stroke

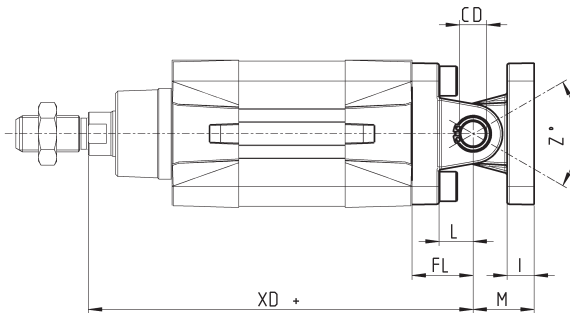
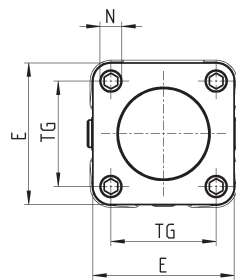

DIMENSIONS												
Mod.	∅	E	TG	\varnothing N	XD+	\varnothing CD	L	FL	I	M	Z° (max)	torque force
C+L+S	32	45	32.5	6.5	142	10	12	22	10	22	30	5 Nm
C+L+S	40	53.5	38	6.5	160	12	15	25	10	25	40	5 Nm
C+L+S	50	62.5	46.5	9	170	12	15	27	12	27	25	10 Nm
C+L+S	63	73	56.5	9	190	16	20	32	12	32	36	10 Nm
C+L+S	80	92	72	11	210	16	24	36	12	36	34	15 Nm
C+L+S	100	108.5	89	11	230	20	29	41	12	41	38	15 Nm
C+L+S	125	132	110	13	275	25	30	50	25	50	30	20 Nm

90° male trunnion Mod. ZC

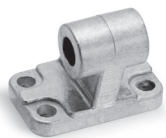

CETOP RP 107P
Material: Aluminium

Supplied with:
1x male support

+ = add the stroke

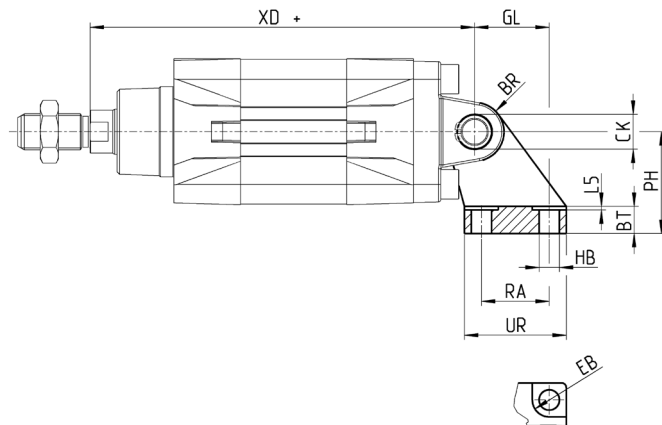
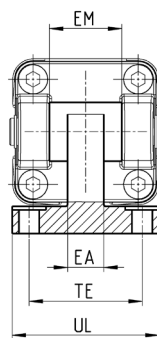

DIMENSIONS																
Mod.	∅	EB	CK	HB	XD+	TE	UL	EA	GL	L5	RA	EM	UR	PH	BT	BR
ZC-32	32	11	10	6,6	142	38	51	10	21	1,6	18	26	31	32	8	10
ZC-40	40	11	12	6,6	160	41	54	15	24	1,6	22	28	35	36	10	11
ZC-50	50	15	12	9	170	50	65	16	33	1,6	30	32	45	45	12	13
ZC-63	63	15	16	9	190	52	67	16	37	1,6	35	40	50	50	14	15
ZC-80	80	18	16	11	210	66	86	20	47	2,5	40	50	60	63	14	15
ZC-100	100	18	20	11	230	76	96	20	55	2,5	50	60	70	71	17	19
ZC-125	125	20	25	14	275	94	124	30	70	3,2	60	70	90	90	20	22,5

Trunnion ball-joint Mod. R*

* This trunnion doesn't comply with the ISO 15552 standard
Material: Aluminium

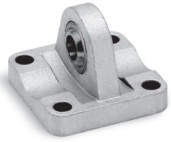

Supplied with:
1x trunnion ball joint
4x screws

+ = add the stroke

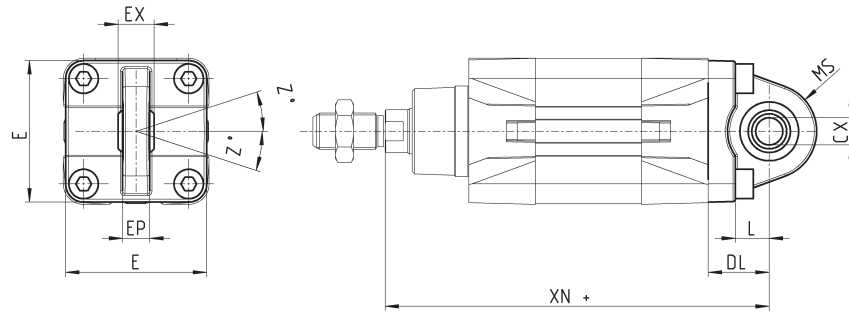

Mod.	∅	∅CX	L	DL	XN+	MS	E	EX	EP	Z	torque force
R-41-32	32	10	12	22	142	18	45	14	10.5	4	5 Nm
R-41-40	40	12	15	25	160	18	53.5	16	12	4	5 Nm
R-41-50	50	12 *	15	27	170	21	62.5	16 *	12 *	4	10 Nm
R-41-63	63	16	20	32	190	23	73	21	15	4	10 Nm
R-41-80	80	16 *	24	36	210	28	92	21 *	15 *	4	15 Nm
R-41-100	100	20	29	41	230	30	108.5	25	18	4	15 Nm
R-41-125	125	30	30	50	275	40	140	37	25	4	20 Nm

Counter bracket for centre trunnion Mod. BF

Material: Aluminium



Supplied with:
2x supports

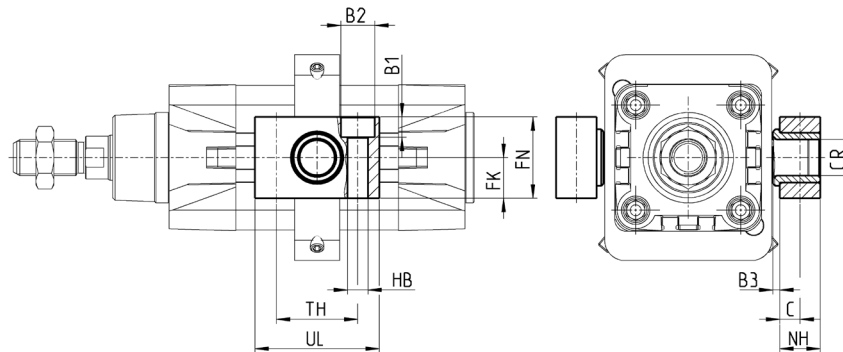

Mod.	∅	∅CR	NH	C	B3	TH	UL	FK	FN	B1	B2	HB
BF-32	32	12	15	7,5	3	32	46	15	30	6,8	11	6,6
BF-40-50	40 - 50	16	18	9	3	36	55	18	36	9	15	9
BF-63-80	63 - 80	20	20	10	3	42	65	20	40	11	18	11
BF-100-125	100 - 125	25	25	12,5	3,5	50	75	25	50	13	20	14

Accessory to mount valves on the cylinder

The mounting sub-base Mod. PCV enables the valve or solenoid valve to be mounted directly on the cylinder.

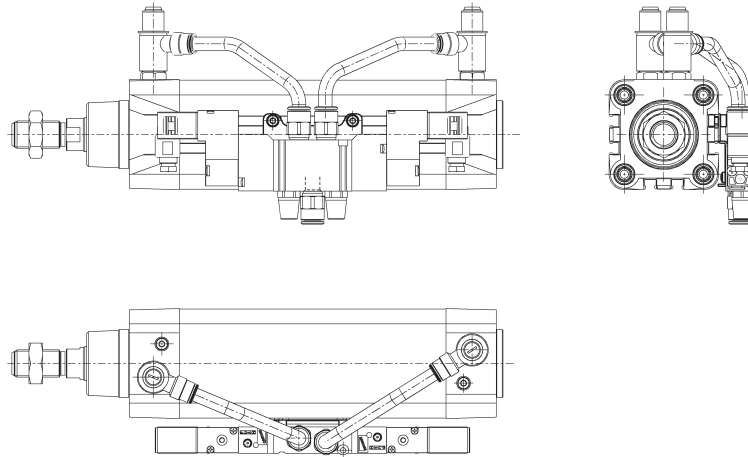

DIMENSIONS	
Mod.	
PCV-61-K3	to connect valves - solenoid valves Series 3
PCV-61-K4	to connect valves - solenoid valves Series 4 port G1/4
PCV-62-KEN	to connect valves - solenoid valves Series EN
PCV-61-K8	to connect valves - solenoid valves Series 4 port G1/8 and Series 3 port G1/4

Clevis pin Mod. S



Supplied with:
 1x clevis pin in stainless steel 303
 2x Seeger in steel

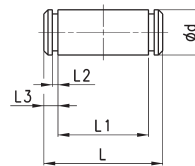

DIMENSIONS							
Mod.	Ø	d	L	L1	L2	L3	
S-32	32	10	52	46	1,1	3	
S-40	40	12	59	53	1,1	3	
S-50	50	12	67	61	1,1	3	
S-63	63	16	77	71	1,1	3	
S-80	80	16	97	91	1,1	3	
S-100	100	20	121	111	1,3	5	
S-125	125	25	140,5	132	1,3	4,25	

Swivel ball joint Mod. GA



ISO 8139.
Material: zinc-plated steel.

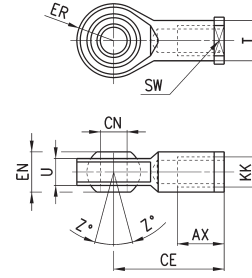

Mod.	$\varnothing_{CN}^{(H7)}$	U	EN	ER	AX	CE	KK	\varnothing_T	Z	SW
GA-32	10	10,5	14	14	20	43	M10X1,25	15	6,5	17
GA-40	12	12	16	16	22	50	M12X1,25	17,5	6,5	19
GA-50-63	16	15	21	21	28	64	M16X1,5	22	7,5	22
GA-80-100	20	18	25	25	33	77	M20x1,5	27,5	7	30
GA-41-125	30	25	37	37	51	110	M27x2	40	7,5	41

Piston rod socket joint Mod. GY



Material: zama and zinc-plated steel.

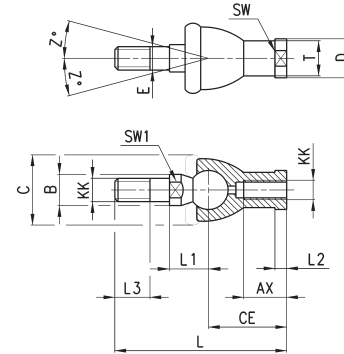

DIMENSIONS																
Mod.	\varnothing	KK	L	CE	L2	AX	SW	SW1	L1	L3	\varnothing_T	\varnothing_D	E	\varnothing_B	\varnothing_C	Z
GY-32	32	M10X1,25	74	35	6,5	18	17	11	19,5	15	15	19	10	14	28	15
GY-40	40	M12X1,25	84	40	6,5	20	19	17	21	17	17,5	22	12	19	32	15
GY-50-63	50-63	M16X1,5	112	50	8	27	22	19	27,5	23	22	27	16	22	40	11
GY-80-100	80-100	M20x1,5	133	63	10	38	30	24	31,5	25	27,5	34	20	27	45	7,5

Rod fork end Mod. G

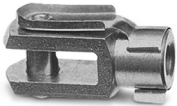

ISO 8140
Material: zinc-plated steel

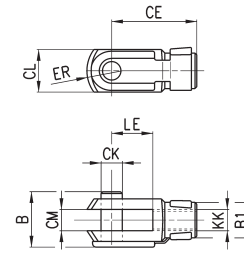

Mod.	\varnothing_{CK}	LE	CM	CL	ER	CE	KK	B	\varnothing_{B1}
G-25-32	10	20	10	20	12	40	M10 X 1,25	26	18
G-40	12	24	12	24	14	48	M12 X 1,25	32	20
G-50-63	16	32	16	32	19	64	M16 X 1,5	40	26
G-80-100	20	40	20	40	25	80	M20 X 1,5	48	34
G-41-125	30	54	30	55	38	110	M27 X 2	74	48

Piston rod lock nut Mod. U



ISO 4035
Material: zinc-plated steel.

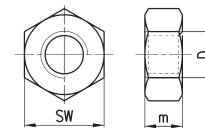

Mod.	D	m	SW
U-25-32	M10X1,25	6	17
U-40	M12X1,25	7	19
U-50-63	M16X1,5	8	24
U-80-100	M20x1,5	9	30
U-41-125	M27x2	12	41

Self aligning rod Mod. GK

Material: zinc-plated steel.

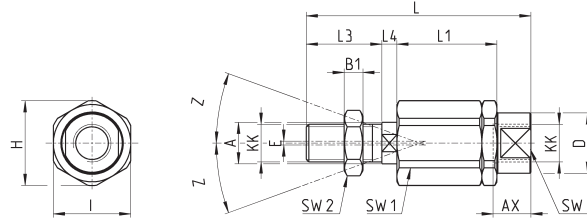

DIMENSIONS																	
Mod.	∅	KK	L	L1	L3	L4	g_A	g_D	H	I	SW	SW1	SW2	B1	AX	Z	E
GK-25-32	25-32	M10x1,25	71,5	35	20	7,5	14	22	32	30	19	12	17	5	22	4	2
GK-40	40	M12x1,25	75,5	35	24	7,5	14	22	32	30	19	12	19	6	22	4	2
GK-50-63	50-63	M16x1,5	104	53	32	10	22	32	45	41	27	20	24	8	30	3	2
GK-80-100	80-100	M20x1,5	119	53	40	10	22	32	45	41	27	20	30	10	37	3	2
GK-125	125	M27x2	147	60	54	10	32	57	70	65	54	24	41	12	48	4	2

Coupling piece Mod. GKF

Material: zinc-plated steel.

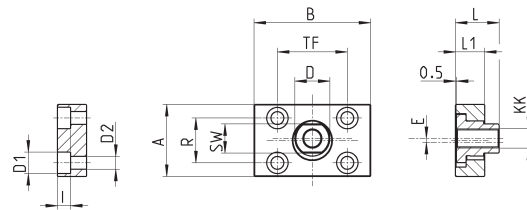

DIMENSIONS														
Mod.	∅	KK	A	B	R	TF	L	L1	I	∅ D	∅ D1	∅ D2	SW	E
GKF-25-32	32	M10x1,25	37	60	23	36	22,5	15	6,8	18	11	6,6	15	2
GKF-40	40	M12x1,25	56	60	38	42	22,5	15	9	20	15	9	15	2,5
GKF-50-63	50-63	M16x1,5	80	80	58	58	26,5	15	10,5	25	18	11	22	2,5
GKF-80-100	80-100	M20x1,5	90	90	65	65	32,5	20	13	30,5	20	14	27	2,5
GKF-125	125	M27x2	90	90	65	65	35,5	20	13	40	20	14	36	4

Special key to disassemble cylinders ∅ 80 and 100

Material: hardened steel

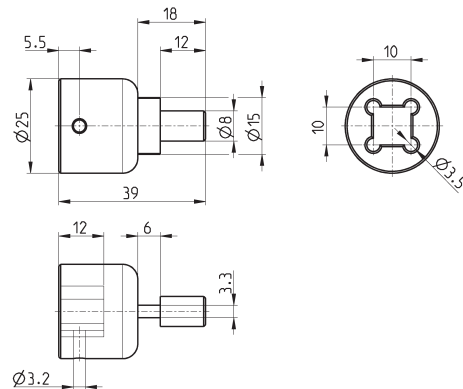
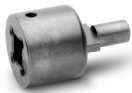

Mod.
80-62/8C