

**MOTORIDUTTORI E RIDUTTORI  
 A VITE SENZA FINE CHM**

**CHM WORM GEARED MOTORS  
 AND WORM GEAR UNITS**



# POSIZIONE DI MONTAGGIO - MOUNTING POSITION

**B3**

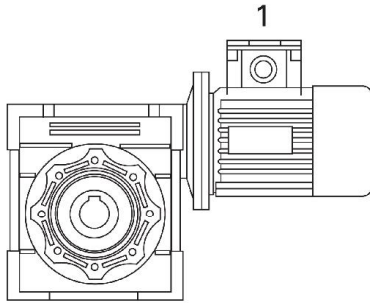

**B6**

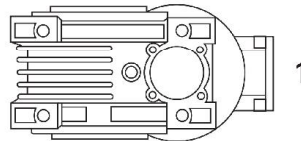

**V5**

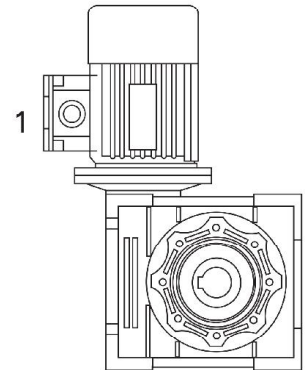

**B7**

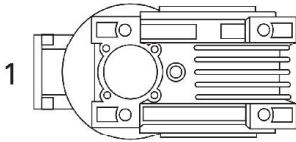

**B8**

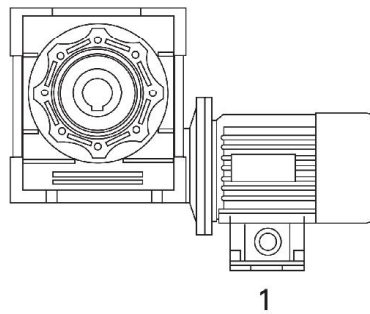

**V6**

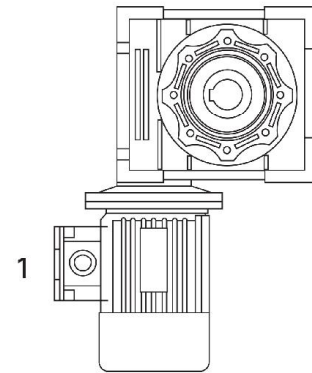

**F...1**

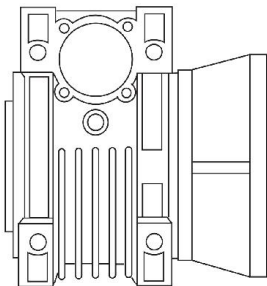

**F...2**

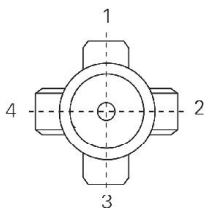
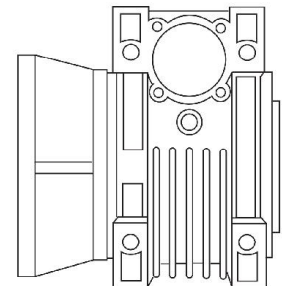

**B3**

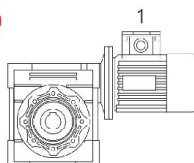

## POSIZIONE MORSETTERIA

N.B. la posizione della morsetteria si riferisce sempre alla pos. B3

## TERMINAL BOX POSITION

N.B. The position of the terminal box always refers to the B3 position.



CHM 150

TIPO	i=ratio	n2 r/min	Kw=P1	Nm=T2	f.s.	Pred. attacco motore possibili	
TYPE	i=ratio	n2 r/min	Kw=P1	Nm=T2	f.s.	Possible types of motor connections	
	7.5	186.7	15	680	1.6	160	B5
	10	140.0	15	905	1.2	160	B5
	15	93.3	15	1310	0.9	160	B5
	20	70.0	11	1270	1.0	160	B5
	25	56.0	11	1520	0.8	160	B5
	30	46.7	7.50	1240	0.8	132	B5
	40	35.0	7.50	1560	0.9	132	B5
	50	28.0	5.50	1405	0.9	132	B5
	60	23.3	5.50	1610	0.8	132	B5
	80	17.5	4	1430	0.8	112/100	B5
	100	14.0	3	1300	0.8	112/100	B5

### DIMENSIONI - DIMENSIONS

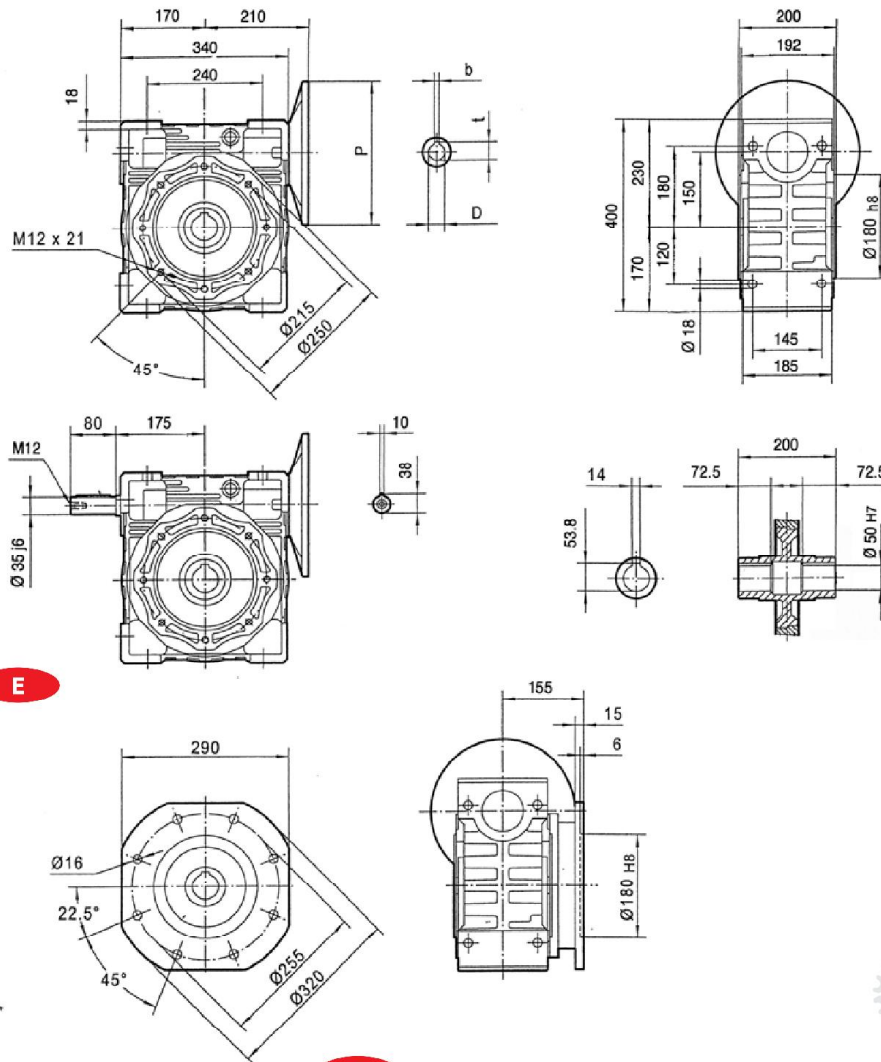

PAM IEC	P	DEs	b	t
160B5	350	42	12	45.3
132B5	300	38	10	41.3
112B5	250	28	8	31.3
100B5	250	28	8	31.3

Peso Kg 84 senza motore  
Weight 84 Kg excluding motor

CHMR	030	040	050	063	075	090	110	130	150
<b>A</b>	20	23	30	40	50	50	60	80	80
<b>D1 j6</b>	9	11	14	19	24	24	28	30	35
<b>B2</b>	51	60	74	90	105	125	142	162	195
<b>B3</b>	45	53	64	75	90	108	135	155	175
<b>a</b>	30	40	50	63	75	90	110	130	150
<b>b1</b>	3	4	5	6	8	8	8	8	10
<b>f1</b>	-	-	M6	M6	M8	M8	M10	M10	M12
<b>t1</b>	10.2	12.5	16	21.5	27	27	31	33	38

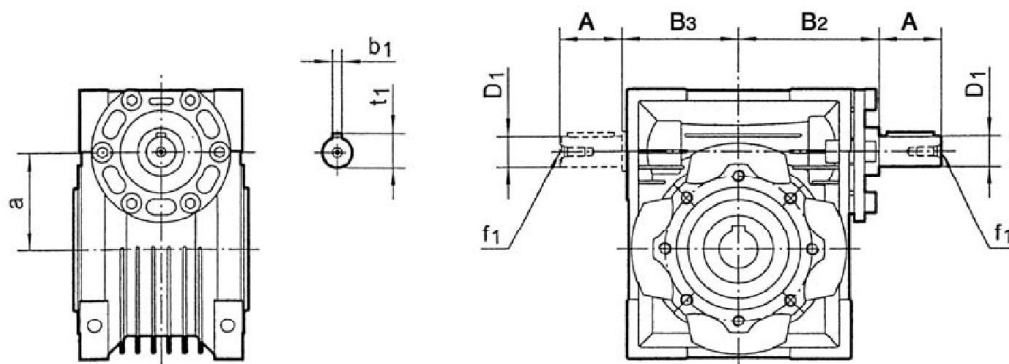

Per le dimensioni mancanti riferirsi al corrispondente CHM  
 For the missing dimensions, please refer to the CHM correspondent



## BRACCIO DI REAZIONE - TORQUE ARM

TIPO - TYPE	I	R	F	H	Ø E	A	B	Ø C	Ø d	Ø P	N°	Peso cad kit kg Weight for kit kg
CHT MV 25*	70	15	17.5	14	8	33.5	118.5	55	7	45	4	0.17
CHT MV 30*	85	15	24	14	8	38	138	65	7	55	8	0.18
CHT MV 40	100	18	31.5	14	10	44	162	75	7	60	8	0.24
CHT MV 50	100	18	38.5	14	10	50	168	85	9	70	8	0.27
CHT MV 63	150	18	49	14	10	55	223	95	9	80	8	0.57
CHT MV 75	200	30	47.5	25	20	70	300	115	9	95	8	1.10
CHT MV 90	200	30	57.5	25	20	80	310	130	11	110	8	1.26
CHT MV 110	250	35	62	30	25	100	385	165	11	130	8	1.92
CHT MV 130	250	35	69	30	25	125	410	215	14	180	8	2.23
CHT MV 150	250	35	84	30	25	125	410	215	14	180	8	2.23

\* Privo di boccola antivibrante  
\* Without vibration resistant bushing

Il punto di ancoraggio del braccio di reazione è dotato di boccola antivibrante.

The anchoring point of the torque arm is equipped with a vibration resistant bushing.

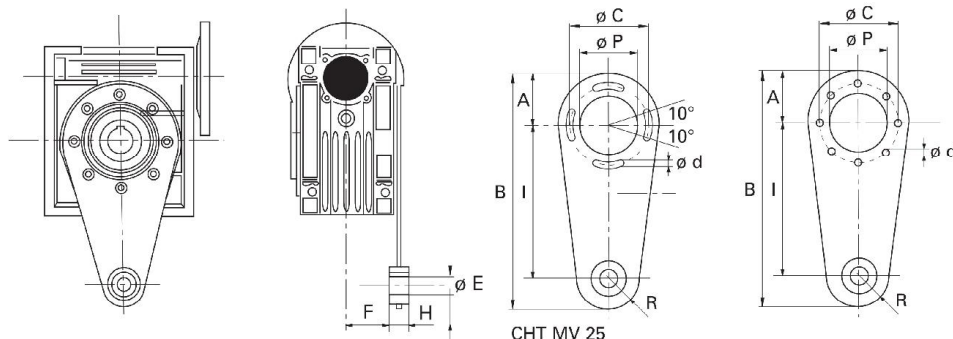

## KIT ALBERO LENTO SEMPLICE - SINGLE OUTPUT SHAFT KIT

TIPO - TYPE	A	Ø d	B	b	t 1	T	L	d 2	Peso cad kit kg Weight for kit kg
CHT MVS 25	23	11	25.5	4	12.5	55.5	81	-	0.07
CHT MVS 30	30	14	32.5	5	16	69.5	102	M6x16	0.14
CHT MVS 40	40	18	43	6	20.5	85	128	M6x16	0.27
CHT MVS 50	50	25	53.5	8	28	99.5	153	M10x22	0.60
CHT MVS 63	50	25	53.5	8	28	119.5	173	M10x22	0.67
CHT MVS 75	60	28	63.5	8	31	128.5	192	M10x22	0.94
CHT MVS 90	80	35	84.5	10	38	149.5	234	M12x28	1.79
CHT MVS 110	80	42	84.5	12	45	164.5	249	M16x35	2.70
CHT MVS 130	80	45	85	14	48.5	180	265	M16x35	3.60
CHT MVS 150	82	50	87	14	53.5	210	297	M16x35	5.00

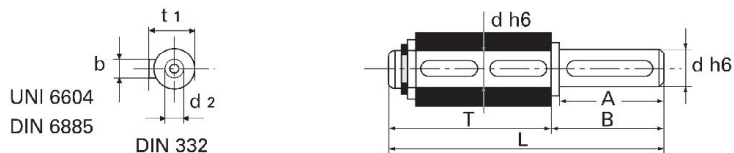

## KIT ALBERO LENTO DOPPIO - DOUBLE OUTPUT SHAFT KIT

TIPO - TYPE	A	Ø d	B	R	b	t 1	L	d 2	Peso cad kit kg Weight for kit kg
CHT MVD 25	23	11	25.5	50	4	12.5	101	-	0.11
CHT MVD 30	30	14	32.5	63	5	16	128	M6x16	0.16
CHT MVD 40	40	18	43	78	6	20.5	164	M6x16	0.34
CHT MVD 50	50	25	53.5	92	8	28	199	M10x22	0.75
CHT MVD 63	50	25	53.5	112	8	28	219	M10x22	0.84
CHT MVD 75	60	28	63.5	120	8	31	247	M10x22	1.20
CHT MVD 90	80	35	84.5	140	10	38	309	M12x28	2.50
CHT MVD 110	80	42	84.5	155	12	45	324	M16x35	3.44
CHT MVD 130	80	45	85	170	14	48.5	340	M16x35	4.25

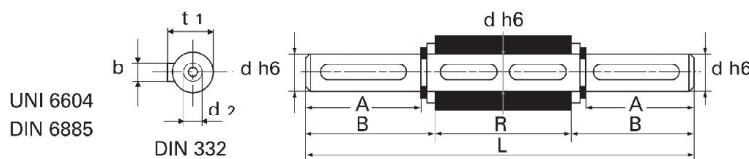



**CHIARAVALLI**<sup>®</sup>  
**GROUP** *SpA*



**RIDUTTORI A VITE SENZA FINE  
CON LIMITATORE DI COPPIA CHML**

**CHML WORM GEARBOXES  
WITH TORQUE LIMITER**