

piSAVE[®] onoff with large hysteresis, 01.18.200

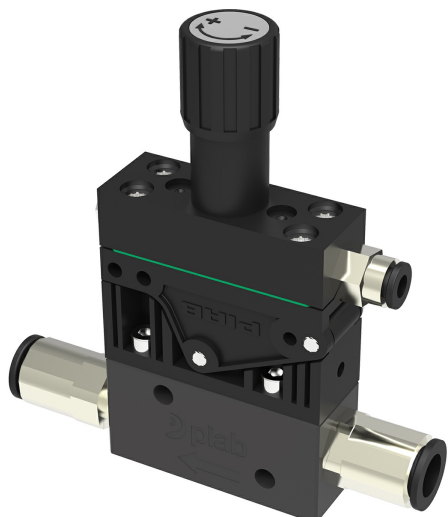

- Independent pneumatic air-saving device for vacuum pumps.
- Adjustable vacuum controlled 2/2 NO valve.
- Available with large hysteresis for object handling and small hysteresis for process applications.
- The Vacustat is recommended for vacuum pumps in non-leaking systems.
- The vacuum pump must be fitted with a non-return valve.

General

Material	CuZn, PA, SS, Al, Nitrile (NBR)
Temperature	32 – 140 °F
Weight	3.63 oz

Performance

Feed pressure, max.	87.0 psi (@ vacuum connection)
Feed pressure, optimum	24.65 – 101.5 psi

Pneumatic data

Flow	15.5 scfm
Life span	10000000 cycles
Valve function	NO

Dimension

Height	3.51 in
Length	0.65 in
Width	1.73 in

Signal function

Hysteresis	7.5 ±2.5 kPa
Signal range	4.43 – 29.23 -inHg

Dimensional drawings

