

BS STANDARD CONNECTIONS

M20882F

**90° BSP O-RING FEMALE
COMPACT ELBOW 60° CONE
BS5200 / ISO 12151-6 (THRUST-WIRE NUT)**

PART. REF.	HOSE BORE			Thread		DIMENSIONS mm						
	DN	Dash	inch			T	B	A	C	E	H1	H2
M20882-04-04F	6	- 4	1/4"	1/4" - 19		4.0	20.0	4.1	22.0	14.0	19.0	
M20882-06-06F	10	- 6	3/8"	3/8" - 19		7.0	23.0	6.0	27.5	19.0	22.0	
M20882-08-08F	12	- 8	1/2"	1/2" - 14		9.3	25.0	6.5	31.0	22.0	27.0	
M20882-10-10F	16	- 10	5/8"	5/8" - 14		12.5	24.5	9.7	32.5	24.0	28.0	
M20882-12-12F	19	- 12	3/4"	3/4" - 14		15.0	37.5	8.5	36.0	27.0	32.0	
M20882-16-16F	25	- 16	1"	1" - 11		20.0	52.0	10.6	44.0	36.0	38.0	

125 FITTINGS

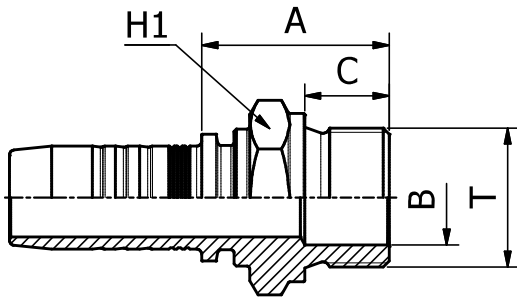

BS STANDARD CONNECTIONS

M10610

BSP MALE FLAT SEAT

PART. REF.	HOSE BORE			Thread		DIMENSIONS mm					
	DN	Dash	inch			T	B	A	C	H1	
M10610-04-04	6	- 4	1/4"	1/4" - 19		6.0	25.5	11.0	19.0		
M10610-06-06	10	- 6	3/8"	3/8" - 19		9.5	28.0	12.0	22.0		
M10610-06-08	10	- 6	3/8"	1/2" - 14		13.0	30.5	14.0	27.0		
M10610-08-08	12	- 8	1/2"	1/2" - 14		13.0	31.0	14.0	27.0		
M10610-10-08	16	- 10	5/8"	1/2" - 14		13.0	31.0	14.0	27.0		
M10610-12-12	19	- 12	3/4"	3/4" - 14		18.0	35.5	16.0	32.0		

BS STANDARD CONNECTIONS

M20612/M20613

BSP FEMALE FLAT SEAT

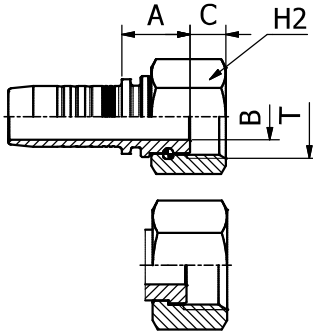

FITTINGS 126

PART. REF.	HOSE BORE			Thread	DIMENSIONS mm							
	DN	Dash	inch		T	B	A	C	H2			
M20612-08-12	12	- 8	1/2"	3/4" - 14		15.0	21.0	11.5	32.0			
M20612-10-12	16	- 10	5/8"	3/4" - 14		15.0	20.5	11.5	32.0			
M20612-12-12	19	- 12	3/4"	3/4" - 14		15.0	22.0	11.5	32.0			
M20612-12-16	19	- 12	3/4"	1" - 11		19.8	23.5	13.0	38.0			
M20612-16-16	25	- 16	1"	1" - 11		19.8	25.0	13.0	38.0			
M20612-20-20	31	- 20	1.1/4"	1.1/4" - 11		26.0	26.0	15.0	50.0			
M20613-04-04	6	- 4	1/4"	1/4" - 19		4.0	14.5	7.9	19.0			
M20613-05-06	8	- 5	5/16"	3/8" - 19		7.0	16.0	9.0	22.0			
M20613-06-06	10	- 6	3/8"	3/8" - 19		7.0	16.5	9.0	22.0			
M20613-06-08	10	- 6	3/8"	1/2" - 14		9.3	17.5	9.8	27.0			
M20613-08-08	12	- 8	1/2"	1/2" - 14		9.3	18.0	9.8	27.0			

SAE STANDARD CONNECTIONS

M12510

JIC MALE 37° CONE
SAE J516 / ISO 12151-5

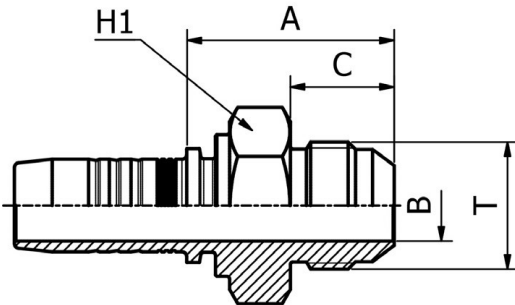

PART. REF.	HOSE BORE			Thread	DIMENSIONS mm							
	DN	Dash	inch		T	B	A	C	H1			
M12510-04-04	6	- 4	1/4"	7/16" - 20		4.0	28.0	14.0	12.0			
M12510-04-05	6	- 4	1/4"	1/2" - 20		5.5	29.0	14.0	14.0			
M12510-04-06	6	- 4	1/4"	9/16" - 18		7.0	29.0	14.0	17.0			
M12510-05-04	8	- 5	5/16"	7/16" - 20		4.0	29.0	14.0	14.0			
M12510-05-05	8	- 5	5/16"	1/2" - 20		5.5	29.0	14.0	14.0			
M12510-05-06	8	- 5	5/16"	9/16" - 18		7.0	29.0	14.0	17.0			
M12510-06-05	10	- 6	3/8"	1/2" - 20		5.5	29.5	14.0	17.0			
M12510-06-06	10	- 6	3/8"	9/16" - 18		7.0	29.5	14.0	17.0			
M12510-06-08	10	- 6	3/8"	3/4" - 16		9.3	34.0	16.5	19.0			
M12510-06-10	10	- 6	3/8"	7/8" - 14		12.5	38.5	19.5	24.0			
M12510-08-06	12	- 8	1/2"	9/16" - 18		7.0	32.0	14.0	19.0			
M12510-08-08	12	- 8	1/2"	3/4" - 16		9.3	34.5	16.5	19.0			
M12510-08-10	12	- 8	1/2"	7/8" - 14		12.5	39.0	19.5	24.0			
M12510-08-12	12	- 8	1/2"	1.1/16" - 12		15.0	43.0	22.0	27.0			
M12510-10-10	16	- 10	5/8"	7/8" - 14		12.5	39.0	19.5	24.0			
M12510-10-12	16	- 10	5/8"	1.1/16" - 12		15.0	42.5	22.0	27.0			
M12510-12-10	19	- 12	3/4"	7/8" - 14		12.5	41.5	19.5	27.0			
M12510-12-12	19	- 12	3/4"	1.1/16" - 12		15.0	44.0	22.0	27.0			
M12510-12-14	19	- 12	3/4"	1.3/16" - 12		15.0	44.5	22.5	32.0			
M12510-12-16	19	- 12	3/4"	1.5/16" - 12		19.8	47.0	23.0	34.0			
M12510-16-12	25	- 16	1"	1.1/16" - 12		15.0	45.0	22.0	32.0			
M12510-16-16	25	- 16	1"	1.5/16" - 12		19.8	48.0	23.0	34.0			
M12510-16-20	25	- 16	1"	1.5/8" - 12		26.0	53.0	24.3	42.0			
M12510-20-20	31	- 20	1.1/4"	1.5/8" - 12		26.0	53.5	24.3	42.0			
M12510-20-24	31	- 20	1.1/4"	1.7/8" - 12		32.0	60.5	27.5	50.0			
M12510-24-24	38	- 24	1.1/2"	1.7/8" - 12		32.0	60.5	27.5	50.0			
M12510-32-32	51	- 32	2"	2.1/2" - 12		42.0	72.0	34.0	65.0			