

DISTRIBUTORE MONOBLOCCO
MONOBLOCK VALVE
MONOBLOCKWEGEVENTILE

Qn
50 l/min

Q max
60 l/min

BM 50

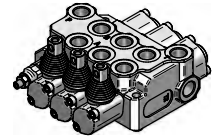
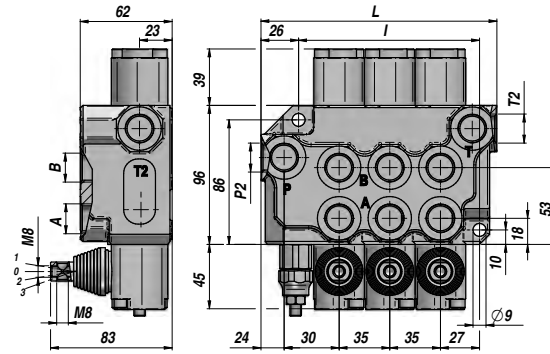
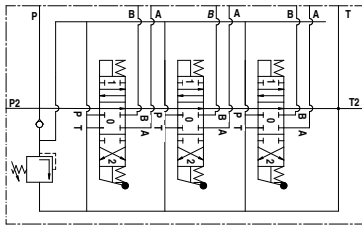

Codice Code Bestell-Nr.	Tipo Type Typ	N° sezioni Sections No. Sektionen-Nr.	Filetti - Threads - Gewinde					PN bar	P MAX U bar	P MAX S bar	L	I	kg
			A-B BSP	P BSP	T BSP	P2 BSP	T2 BSP						
DBM3111001	BM 50/1/GU/MO A1	1									94	55	2,80
DBM3211001	BM 50/2/GU/MO A1x2	2									129	90	4,20
DBM3311001	BM 50/3/GU/MO A1x3	3									164	125	5,50
DBM3411001	BM 50/4/GU/MO A1x4	4	1/2"	1/2"	1/2"	1/2"	1/2"	250	320	80	199	160	6,70
DBM3511001	BM 50/5/GU/MO A1x5	5									234	195	7,90
DBM3611001	BM 50/6/GU/MO A1x6	6									269	230	9,30
DBM3811001	BM 50/8/GU/MO A1x8	8									339	300	12,80

PN = Pressione nominale - Nominal pressure - Nenndruck

P MAX U = Pressione Max. sugli utilizzi - Max. pressure on ports - Max. Druck in den Anschlüssen

P MAX S = Pressione Max. allo scarico - Max. pressure in tank-line - Max Druck am Tank

Valvola Max. Pressione - Relief Valve - DBV: X = 30:90 bar (70) - U = 80:230 bar (140) (Standard) - K = 150:300 bar (200)

I CODICI SONO RIFERITI AI MODELLI - THESE CODES REFER TO - DIE ARTIKELNUMMER BEZIEHEN SICH AUF:

DOPIO EFFETTO - 3 POSIZIONI - RITORNO A MOLLA - A/B CHIUSI - FILETTI BSP - PREDISPOSTO PER CARRY-OVER

DOUBLE ACTING TYPE - 3 POSITIONS - SPRING RETURN - A/B GESCHLOSSEN - BSP GEWINDE - MACHINED FOR CARRY-OVER

D.W. TYPEN - 3 STELLUNGEN - RÜCKFEDER - A/B GESCHLOSSEN - BSP GEWINDE - FÜR DRUCKWEITERLEITUNG GEEIGNET

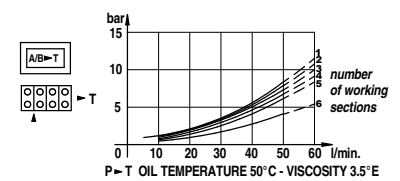
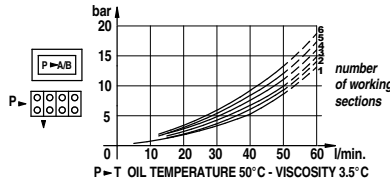
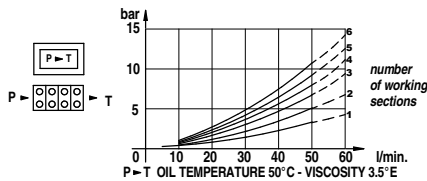

CURSORE SPOOL TYPE - SCHIEBERTYP	
A	
B	
C	
D	
L	
Z	

POSIZIONATORE SPOOL CONTROL - BETÄTIGUNGSART	
1	
2	
3	
6	
7	
8	
12	
42	

A RICHIESTA ON REQUEST - AUF ANFRAGE	
MC	comando manuale + camma manual operator with cam manuelle Betätigung + Zapfen
MX	leva di sicurezza safety lever Sicherheitshebel
DO	comando a camma cam operator Nockensteuerung
JS	manipolatore joystick Joystick
1P	comando pneumatico pneumatic operator pneumatische Betätigung
MSW	microinterruttore microswitch Mikroschalter-Betätigung
CO	proseguimento di pressione power beyond (carry over) Druckweiterleitung
CCP	tappo centro chiuso closed center plug Stopfen für geschlossene Mittelstellung