

Raccordi Femmina BSP sede 60° con O-Ring per Tubi: DIN 20023-4SH EN 856-4SH|SAE 100R13 EN 856-R13|SAE 100R15
 BSP Females 60° Cone with O-Ring for Hoses: DIN 20023-4SH EN 856-4SH|SAE 100R13 EN 856-R13|SAE 100R15
 BSP 60° Dichtkegel mit O-Ring für Schläuche: DIN 20023-4SH EN 856-4SH|SAE 100R13 EN 856-R13|SAE 100R15

ISO 12151-6 (ISO 8434-6)

MDKOR

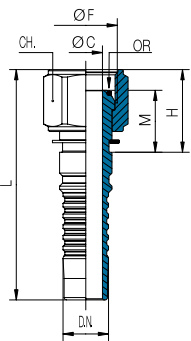

CODICE Part n° Bestell-Nr.	Filetto Thread Gewinde	Ø F ø F ø F	DN Tubo DN Hose DN Schlauch	CH	L	Ø C	H	M	OR
b S 80 41 0 119 019	G 3/4"		3/4" 19	32	96,5	14	34,5	26	17,1x1,6
b S 80 41 0 125 025	G 1"		1" 25	41	113	19	39	28,5	22,1x1,6
b S 80 41 0 132 032	G 1 1/4"		1 1/4" 31	50	126	25	46	36	29,1x1,6
b S 80 41 0 138 038	G 1 1/2"		1 1/2" 38	55	146	31	54,5	42	35,1x1,6
c S 80 41 0 150 050	G 2"		2" 51	70	163	42	59	43	48,1x1,6

MDKOR 90

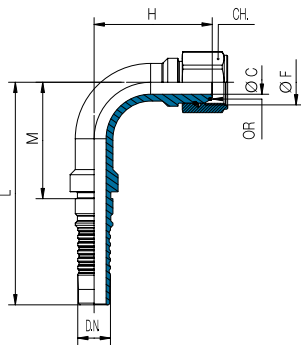

c S 80 53 0 119 019	G 3/4"		3/4" 19	32	127,5	14	68,5	65,5	17,1x1,6
c S 80 53 0 125 025	G 1"		1" 25	41	158	19	82	84	22,1x1,6
c S 80 53 0 132 032	G 1 1/4"		1 1/4" 31	50	182	25	106,5	102	29,1x1,6
c S 80 53 0 138 038	G 1 1/2"		1 1/2" 38	60	215,5	31	123,5	124	35,1x1,6
c S 80 53 0 150 050	G 2"		2" 51	70	248	41	144,5	144	48,1x1,6

MDKOR 45

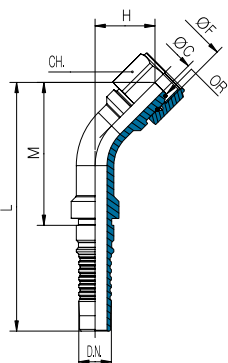

c S 80 83 0 119 019	G 3/4"		3/4" 19	32	140	14	34,5	78	17,1x1,6
c S 80 83 0 125 025	G 1"		1" 25	41	169,5	19	39	95,5	22,1x1,6
c S 80 83 0 132 032	G 1 1/4"		1 1/4" 31	50	201	25	51,5	121	29,1x1,6
c S 80 83 0 138 038	G 1 1/2"		1 1/2" 38	60	235	31	60	143,5	35,1x1,6
c S 80 83 0 150 050	G 2"		2" 51	70	279	41	68,5	175	48,1x1,6

b: dado passante
 c: dado con anello

b: union nut
 c: thrust-wire nut

b: Überwurfmutter
 c: Überwurfmutter mit Drahtstift

Articoli di basso consumo su richiesta
 Slow moving articles available on request
 Artikel mit geringen Stückzahlen auf Anfrage