

VGS™2010,

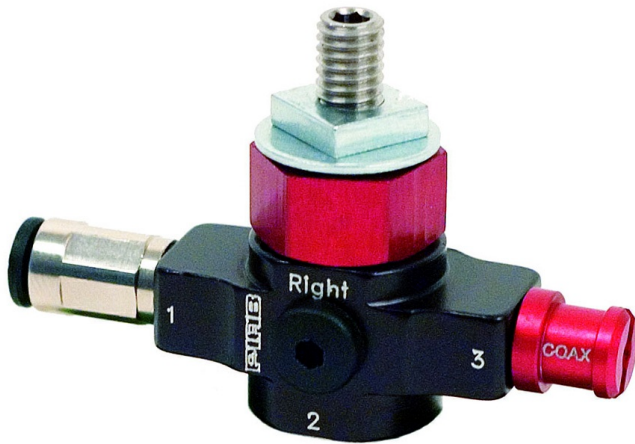

- Patented COAX® technology.
- Compatible with any suction cup with G1/8" male fitting. Suction cup ordered separately.
- Available with a two-stage COAX® cartridge MICRO. Configurable to your specific needs. Choose Bi for low feed pressure, Si for high vacuum flow, Xi for extra vacuum and Ti at 0.4/0.6 MPa for extra capacity/dirt tolerance.

General

Material	PA, SS, TPE, Al, Nitrile (NBR)
Noise level	55 – 61 dBA
Temperature	-10 – 80 °C

Performance

Feed pressure, max.	0.7 MPa
---------------------	---------

Vacuum flow

COAX® Cartridge	Feed pressure MPa	Air consumption NI/s	Vacuum flow (NI/s) at different vacuum levels (-kPa)										Max vacuum -kPa
			0	10	20	30	40	50	60	70	80		
Bi03-2	0.18	0.14	0.23	0.15	0.06	0.04	0.035	0.023	0.013	0.006	—	83	
Si02-2	0.6	0.12	0.28	0.21	0.12	0.08	0.07	0.06	0.04	0.02	—	75	
Xi2.5-2	0.5	0.13	0.24	0.17	0.1	0.06	0.04	0.03	0.02	0.01	0.01	92	
Ti05-2	0.4	0.27	0.32	0.28	0.23	0.17	0.1	0.07	0.04	0.02	0.004	84	
Ti05-2	0.6	0.37	0.31	0.27	0.24	0.2	0.15	0.09	0.04	0.01	—	75	

Evacuation time

COAX® Cartridge	Feed pressure MPa	Air consumption NI/s	Evacuation time (s/l) to reach different vacuum levels (-kPa)									Max vacuum -kPa
			10	20	30	40	50	60	70	80		
Bi03-2	0.18	0.14	0.5	1.4	3.9	6.4	10	16	28	51	83	
Si02-2	0.6	0.12	0.41	1.01	2.01	3.3	4.9	6.9	10.2	—	75	
Xi2.5-2	0.5	0.13	0.49	1.23	2.48	4.5	7.3	11.3	18	28	92	
Ti05-2	0.4	0.27	0.33	0.73	1.2	2	3.1	5	8.3	16.6	84	
Ti05-2	0.6	0.37	0.3	0.7	1.2	1.8	2.6	4.2	8.43	—	75	

Blow flow

COAX® Cartridge	Feed pressure MPa	Air consumption NI/s	Blow flow (NI/s) at different pressure levels (kPa)									Max pressure kPa
			0	10	20	30	40	50	60	70		
Si02-2	0.6	0.12	0.4	0.34	0.22	0.21	0.2	0.18	0.17	0.15	70	

Dimensional drawings

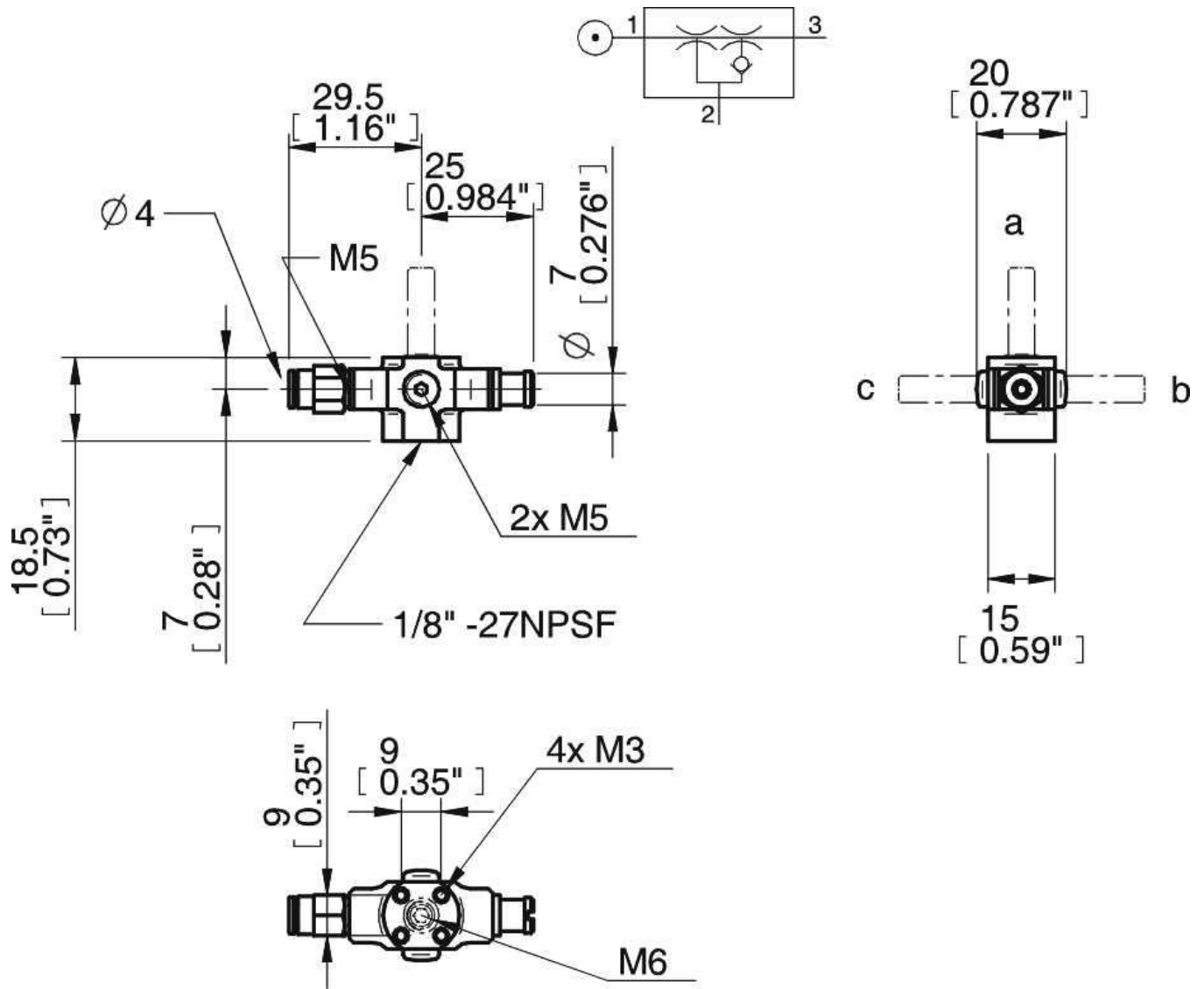

Values specified in the data sheet are tested at:

Room temperature	(20°C [68°F] ± 3°C [5.5°F])
Standard atmosphere	(101.3 [29.9 inHg] ± 1.0 kPa [0.3 inHg])
Relative humidity	0-100%
Compressed air quality	DIN ISO 8573-1 class 4