

# COAX® cartridge MINI Pi12-2, 01.06.922



- Two-stage COAX® cartridge - MINI - with small mounting dimensions.
- Vacuum level to 27 -inHg at low feed pressures.
- High operational reliability in case of fluctuating or low compressed-air pressure.
- Suitable for handling sealed objects.
- Used in PMAT, VGS™3010 and VGS™3040.

## General

Material	PA, SS, Al, Nitrile (NBR)
Temperature	14 – 176 °F
Weight	0.09 – 0.34 oz

## Performance

Feed pressure, max.	102 psi
---------------------	---------

## Vacuum flow

Feed pressure psi	Air consumption scfm	Vacuum flow (scfm) at different vacuum levels (-inHg)										Max vacuum -inHg
		0	3	6	9	12	15	18	21	24		
25	0.61	1.21	0.85	0.47	0.32	0.15	—	—	—	—	14.5	
32	0.72	1.36	1.02	0.61	0.42	0.3	0.17	0.04	—	—	18.9	
46	0.93	1.44	1.27	0.93	0.57	0.4	0.3	0.21	0.13	0.06	26.6	
58	1.12	1.4	1.27	1.1	0.83	0.51	0.25	0.21	0.13	0.04	24.8	

## Evacuation time

Feed pressure psi	Air consumption scfm	Evacuation time (s/cf) to reach different vacuum levels (-inHg)								Max vacuum -inHg
		3	6	9	12	15	18	21	24	
25	0.61	7.93	15.9	32	60.3	—	—	—	—	14.5
32	0.72	5.66	11.9	24.1	42.5	65.1	85	—	—	18.9
46	0.93	4.81	9.06	16.4	31.1	51	76.5	113	181	26.6
58	1.12	5.1	9.34	15.3	24.1	42.5	70.8	108	201	24.8

## Blow flow

Feed pressure psi	Air consumption scfm	Blow flow (scfm) at different pressure levels (psi)												Max pressure psi
		0	3	6	9	10	12	13	15	16	17	19	20	
87	1.59	2.9	2.88	2.82	2.37	2.18	2.18	2.18	2.18	2.12	2.01	1.82	1.67	20

## Dimensional drawings

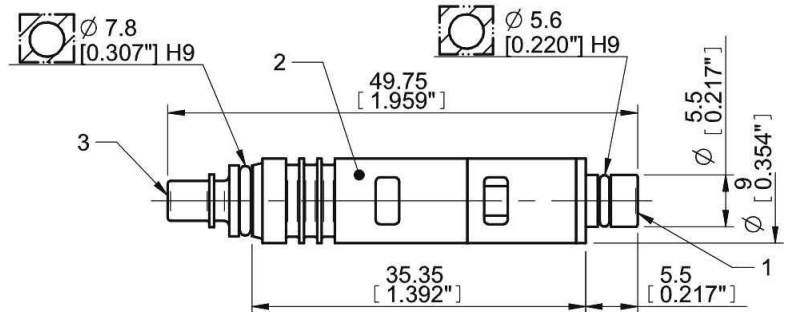
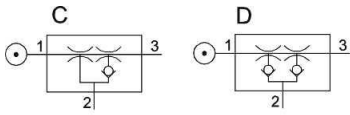

## Values specified in the data sheet are tested at:

Room temperature	(20°C [68°F] ± 3°C [5.5°F])
Standard atmosphere	(101.3 [29.9 inHg] ± 1.0 kPa [0.3 inHg])
Relative humidity	0-100%
Compressed air quality	DIN ISO 8573-1 class 4

## Accessories

	Part no.
Silencer COAX® MINI	01.11.977